



# The new G-Class.

CROSS-COUNTRY VEHICLE.



# Stronger than time.

Some time ago, a group of engineers in Stuttgart and Graz developed an all-new genetic code: the DNA of a cross-country vehicle – iconic, robust and almost indestructible. They constructed parts whose functions even now fulfil their purpose in the same way. Components which, over generations, have combined to form a unique character. They created a design which eschewed short-lived trends and thought nothing of fancy gimmickry. A timeless vehicle which, over time, was to become a legend – stronger than time.

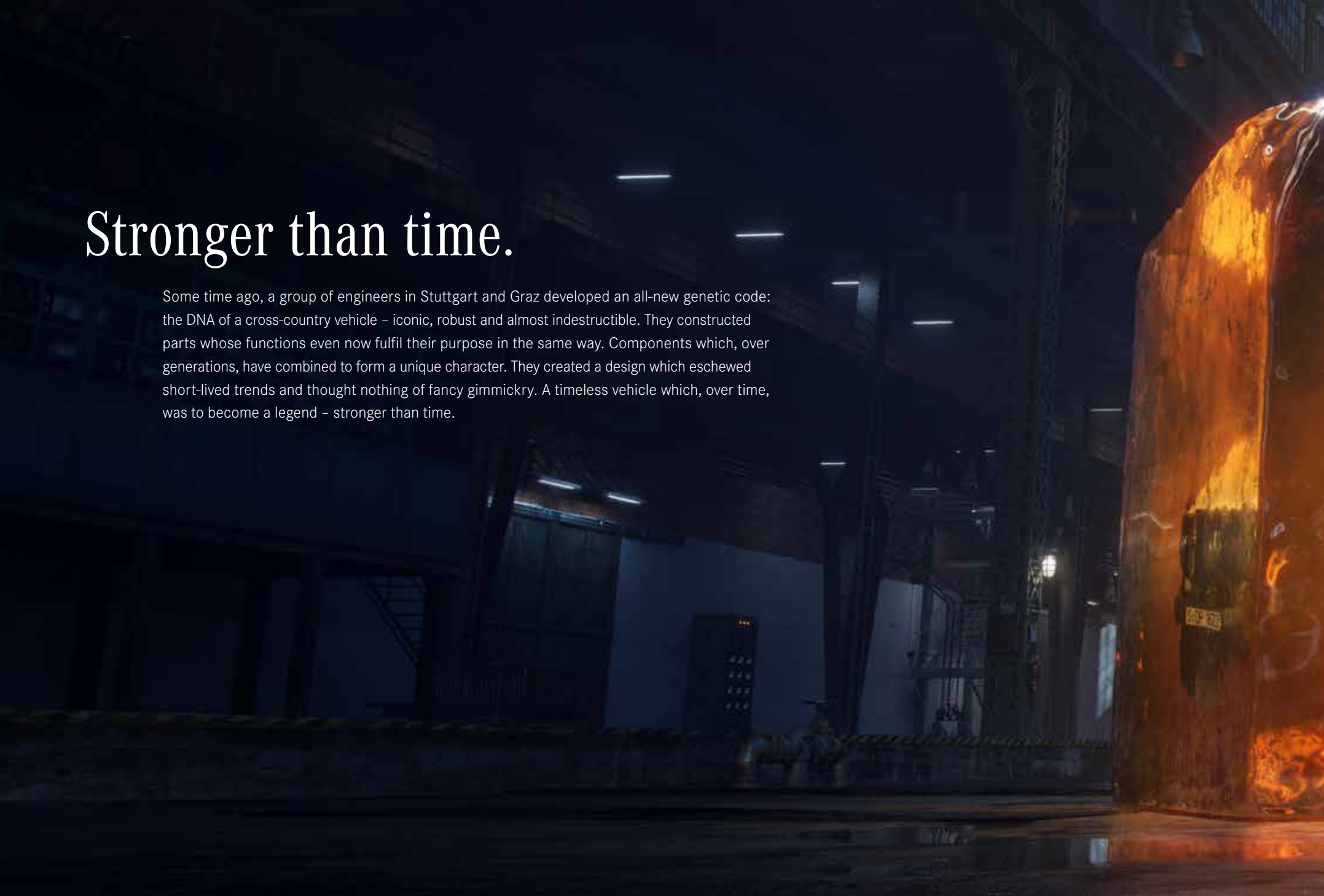





# State-of-the-art legend.

Welcome to the end of the world. The new G-Class is already there. It's everywhere. Continuing the tradition of a vehicle built for the most extreme conditions. The G-Class feels different to the mainstream, particularly in places where other vehicles dare not tread. As if these places were just made for it. Join us on a journey to the holy grail of mobility. Discover the new G-Class.

## The many guises of immortality.

### 04 | Mercedes-Benz G 500

#### designo citrine brown magno

5-spoke light-alloy wheels, painted in matt black, Stainless Steel package, radiator with chrome trim, MULTIBEAM LED, Exclusive interior, Active Multicontour Seat package, designo two-tone nappa leather upholstery in platinum white/black, metal-structure trim

### 18 | Mercedes-Benz G 500

#### emerald green metallic

AMG Line, AMG multi-spoke light-alloy wheels, painted in black with a high-sheen finish, Stainless Steel package, leather upholstery in nut brown/black, open-pore natural walnut wood trim

### 28 | Mercedes-AMG G 63

#### designo diamond white bright

AMG cross-spoke forged wheels, painted in titanium grey with a high-sheen finish, MULTIBEAM LED, Exclusive Plus interior, Active Multicontour Seat package, AMG Exclusive nappa leather upholstery in macchiato beige/espresso brown, AMG carbon-fibre trim

## Giants in detail.

40 | AMG engineering highlights

42 | Production facility in Graz

48 | The Schöckl

50 | The G-Class DNA

52 | G-Class milestones

56 | Ladder frame

58 | Differential locks and reduction gear

60 | Axle architecture

62 | G 500 engine

64 | Model variants

68 | Equipment packages

74 | designo manufaktur

78 | Optional extras

80 | Mercedes-Benz Intelligent Drive and DYNAMIC SELECT

81 | Parking packages

82 | The new telematics generation in the G-Class

84 | Genuine accessories

86 | Wheels

88 | The AMG world

90 | Mercedes me

92 | Off-road ability

94 | Dimensions and technical data

96 | Upholstery, trim and paintwork

G 500 urban/extra-urban/combined fuel consumption: 14.1/10.8/12.1 l/100 km, combined CO<sub>2</sub> emissions: 276 g/km.

Mercedes-AMG G 63 urban/extra-urban/combined fuel consumption: 16.5/11.1/13.1 l/100 km, combined CO<sub>2</sub> emissions: 299 g/km.

The figures shown were obtained in accordance with the prescribed measuring process. They are "NEDC CO<sub>2</sub> values" pursuant to Art. 2 No. 1 Implementing Regulation (EU) 2017/1153. The fuel consumption figures were calculated on the basis of these figures. The figures are not based on an individual vehicle and do not constitute part of the product offer; they are provided solely for purposes of comparison between different vehicle models. The figures vary depending on the selected optional extras.

A dark grey SUV is parked on a rocky, desert landscape. The vehicle is shown from a rear three-quarter view, highlighting its rugged design and large tires. The background consists of layered, reddish-brown rock formations under a clear sky. The word "Stronger" is overlaid in a large, white, serif font across the center of the image.

# Stronger



than rock.





A Mercedes-Benz G-Class vehicle is shown from a rear-quarter perspective, driving through a desert landscape. The vehicle is kicking up a massive, dense cloud of sand and dust that fills the lower half of the frame. The background consists of rolling sand dunes under a clear blue sky. The overall scene conveys a sense of ruggedness and off-road capability.

## A monolith forges ahead.

The dune looms relentlessly. Picking a route through the giant sand hills is anybody's guess. But the new G-Class remains unperturbed – slicing through the terrain, merging with its surroundings, becoming one with nature. It powers across the wasteland, cuts a swathe through the desert, literally moves mountains a little piece at a time. And then comes to a halt. Made it! Majestically it surveys its terrain and celebrates its triumph. This is its destiny. Its character. Its DNA.



# Ahoy.

The G-Class does things “as the crow flies”. Even in the water. The spray rises up menacingly. A tidal wave slaps into the bank. The legend channels its way along the riverbed. Where others look for bridges, the G-Class takes the direct route. Thanks to its fording depth of 70 cm, the new G-Class appears to be one with the water. Right up until the driver reaches the opposite bank. With the G-Class, there’s no danger of getting your feet wet. Land ahoy!

# Securely in place.

Hold your breath. Ahead lies nothing but rugged rock and steep slopes. Blocking the view but not the route. Thanks to a low centre of gravity which enhances its off-road capability, the new G-Class is utterly unfazed as it manoeuvres up and down the gradients. Its unique design helps it to remain stable even when tilted to the extreme – up to 35° – with consummate ease. So the only thing which seems to be askew is the horizon.



# As high as it gets.

The gradient really starts to rise as the summit approaches, putting the vehicle in an extreme position. All that is visible through the windscreen is sky. And it's getting closer and closer. Yet the new G-Class continues its inexorable ascent unblinkingly, surmounting the peak at its trickiest point. For generations, the G-Class has displayed nothing but total commitment. And thanks to 100% gradeability, it scales gradients up to 45° steep with the accustomed aplomb. Only to climb down again nonchalantly on the other side.



# Endless expanses.

It's as if nature has acted as the model for the generously appointed, spacious interior of the new G-Class – which provides outstanding comfort in even the most inhospitable of surroundings. The new space concept makes the G-Class a paragon of comfort and spaciousness for all occupants. Even the interior design has taken a quantum leap forward. Those who love freedom and exceptional design will find both here.











A dark green SUV is parked on a rugged, moss-covered rocky terrain. The vehicle is positioned on the right side of the frame, with its rear and side visible. The background consists of a steep, mossy hillside. The text "Stronger th" is overlaid in a large, white, serif font across the center of the image.

Stronger th



an zeitgeist.

# Enhanced rather than changed.

There are moments in which time seems to stand still. Reverential silence then reigns supreme. The G-Class is made for moments like these. There can be no doubt: it is timeless. Thanks to its characteristic design. Its corners and edges are still there. Even though the entire vehicle has been almost completely revised. The new G-Class is over 12 cm wider and 5 cm longer, for example. The expanded interior offers substantially more comfort on campaigns of conquest around the world.









# We all hold on to certain things.

After almost 40 years, it was time for some big decisions. Starting with the grab handle – which stays where it is. Indispensable in off-road terrain, the handle is also a key element of the interior's characteristic design. It is just as much a part of the unmistakable DNA of the G-Class as the spare wheel, door handles and direction indicators – all iconic features which have defined the distinctive appearance of the G-Class for generations. Another thing which remains is the vital hub for successful off-road progress: the prominent buttons for the three differential locks. There are also plenty of changes, however: the fully revised interior design scales new heights. Here the design idiom and the interior proportions leave no doubt that this is the G-Class: confident, chiselled, iconic.



# Intelligence squared.

With no natural enemies off the road, it's hardly surprising that it wants to call the shots on the road, too. The new G-Class impresses thanks to its axle architecture with exact wheel location, precise steering and, consequently, tangibly enhanced on-road performance. In addition to this, a wealth of assistance systems further enhances road safety. Intelligent Drive, included as standard, makes the off-roader the most intelligent G-Class of all time. All for when the G wants to show what it can do away from the wild.





# Stronger th

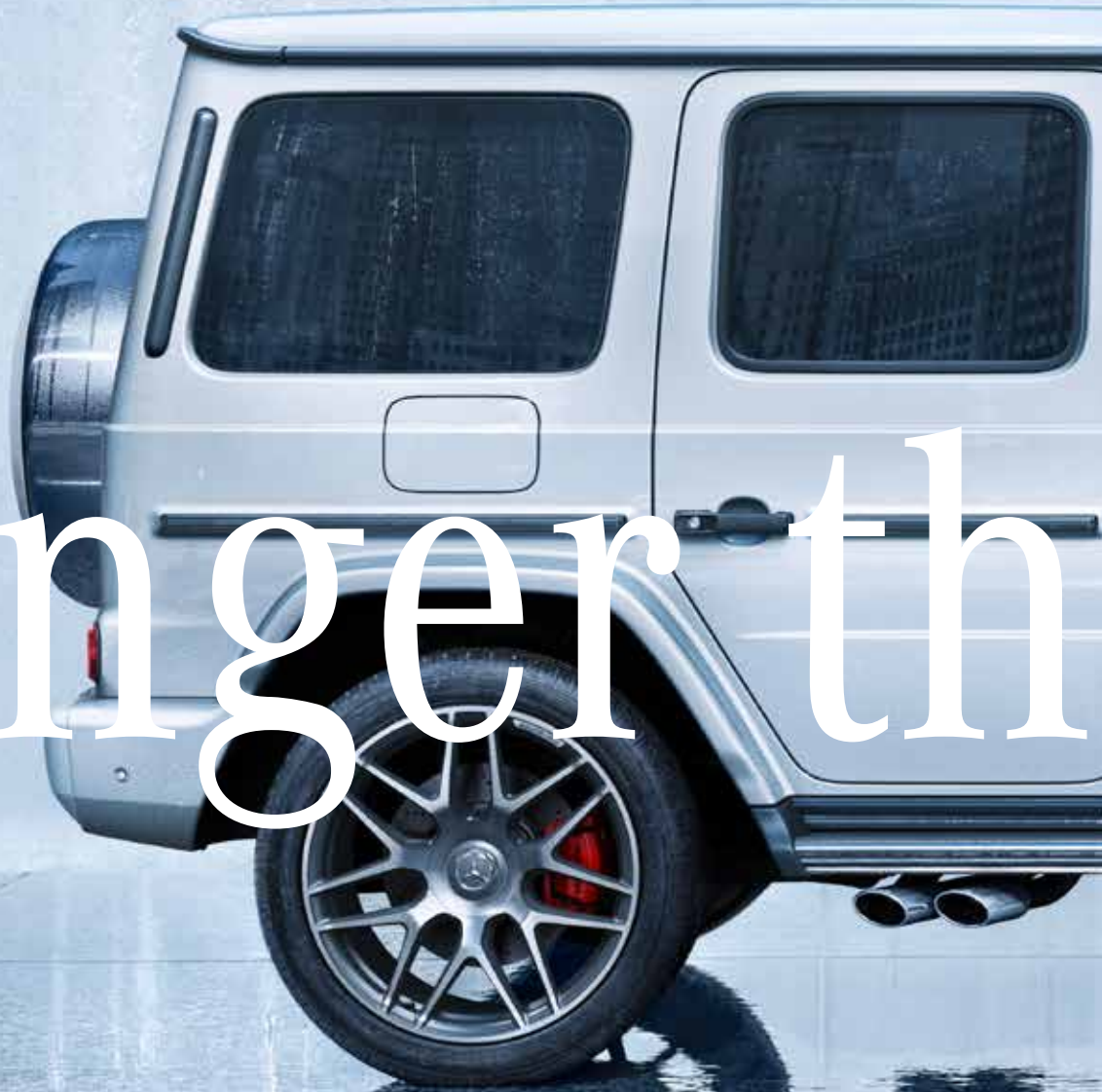



an asphalt.







## Big Bang in the city.

The road seems to be melting. Or is it the shiny film of the water fountain? It's all the same to the new Mercedes-AMG G 63. With its impressive and expressive exterior design. A look that leaves no doubt as to who's in charge. The AMG-specific radiator trim, the optionally available 55.9 cm (22-inch) wheels and the striking side-exiting AMG performance exhaust system lend the icon its extrovert exterior. The Mercedes-AMG G 63 makes no distinction between lava and asphalt. Delivering performance at the limit every time. It has always been without equal off the road. But the off-road giant also impresses in the city thanks to its effortlessly superior handling, making it a king away from the wild, too – in the urban jungle.



# Enthroned above it all.

The G-Class knows no limits. And that goes for the interior, too. Its outward appearance may have changed little, but inside the new G-Class is almost unrecognisable. The new Mercedes-AMG G 63 likewise stays faithful to the DNA: corners and edges are also prominent in the off-roader's interior. And the vehicle offers tangibly more space for all occupants. Newly designed seats upholstered in the finest AMG Exclusive nappa leather with diamond stitching and "AMG" badge give a feeling of security – while the massage function provides relaxation whether in the heart of the city or as far away from civilisation as it gets.

# Extraordinary appearance.

A giant slips smoothly through the urban canyons. For all its power, the new G-Class also delivers vastly improved ride comfort on the road. The effortless superiority with which the off-roader moves through the city draws admiring glances as if by magic. The same thing happens at night: see and be seen. For this, the new G-Class features innovative lighting technology. The LED High Performance headlamps create a pleasant sensation of light which is similar to daylight and in tune with the way we see things – for more relaxed driving in the dark. All with a breathtaking design that makes the new G-Class really catch the eye.





# Hi, way.

A muffled rumble announces its arrival. The ground starts to shake. The air begins to vibrate. Then the G-Class turns the corner. Miles of highway opening up before it. It accelerates and starts to really shift. Unfamiliar terrain? On the contrary. Those who think the new G-Class is only in its element off the road couldn't be more wrong. On the road, it soon becomes clear that the off-roader knows no compromise. Thanks to the newly developed AMG RIDE CONTROL suspension and the speed-sensitive sports steering, the new Mercedes-AMG G 63 delivers outstanding on-road performance. When on the move, dynamism and comfort scale new heights and take the driving enjoyment to levels with which G-Class off-road drivers have long been familiar.









# Security and thunder.

The G-Class combines opposites. Two hearts beat at its core. One wild, one mild. Here luxury meets adventure, and ruggedness is paired with protection. In the interior of the new Mercedes-AMG G 63, high-quality materials and high-class appeal lift the atmosphere to a new level and convey a feeling of absolute security. A sporty AMG performance steering wheel makes the dynamism of the new Mercedes-AMG G 63 tangible in every movement. The new COMAND Online assists the driver with additional functions which make every trip so much easier. Optional ambient lighting bathes the interior in one of 64 selectable light moods while the optional Burmester® surround sound system treats the occupants to an intense listening experience of the highest quality.

# The epicentre of strength.

Filigree technology meets monumental sound. The new Mercedes-AMG G 63 with AMG 4.0-litre V8 biturbo engine, an output of 430 kW (585 hp), and a peak torque of 850 Nm makes every trip an intense experience. Both for the occupants and for those at the side of the road. The adjustable AMG performance exhaust system makes the air vibrate and allows the driver to choose their own sound: from understated for long-distance cruising to highly emotive for rapid bursts of speed. AMG RIDE CONTROL lets the driver adjust the suspension at the push of a button, enabling the new Mercedes-AMG G 63 to adapt to the current on or off-road terrain as well as to individual driver requirements.

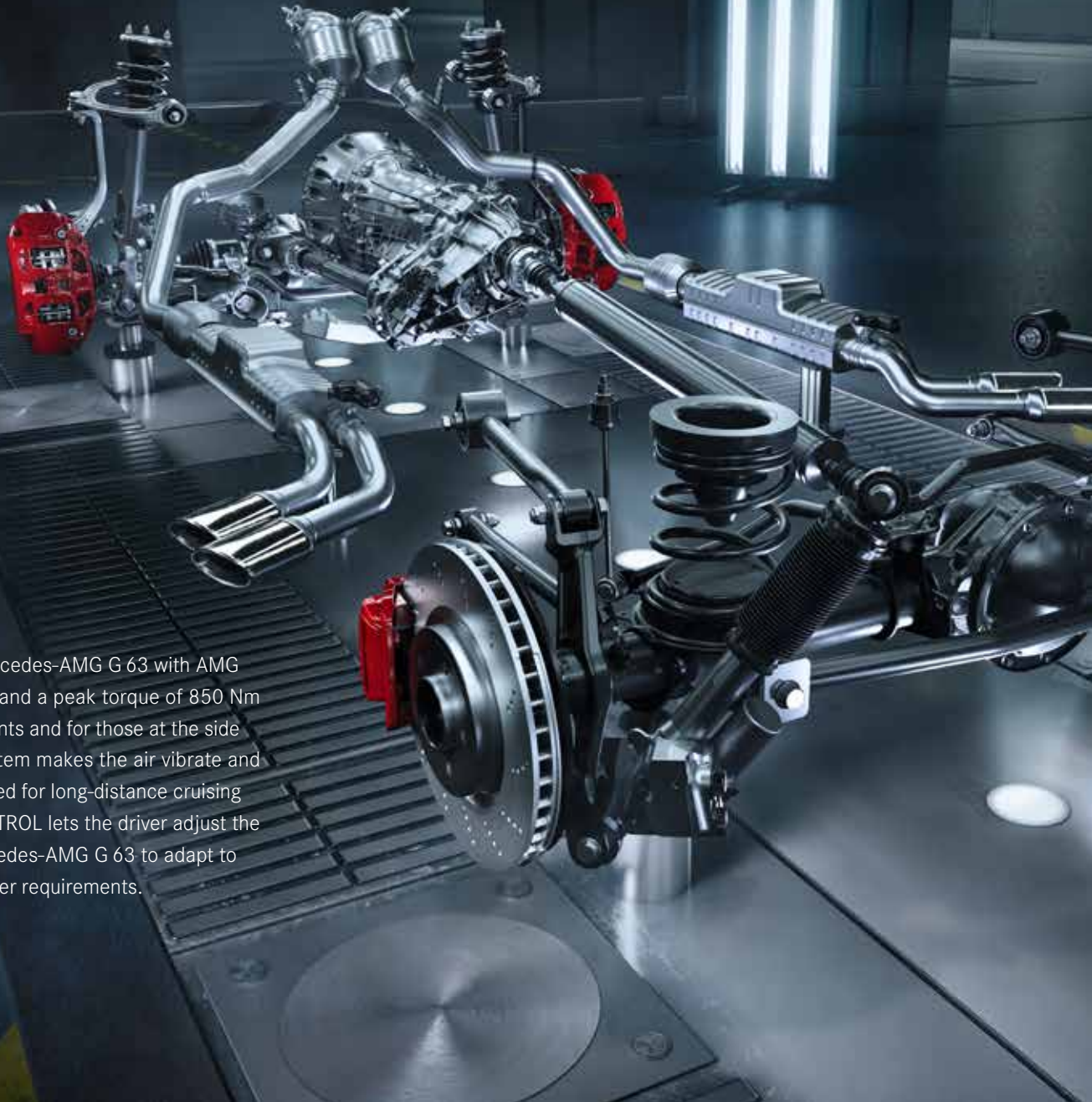



Mercedes-AMG G 63 urban/extra-urban/combined fuel consumption: 16.5/11.1/13.1 l/100 km, combined CO<sub>2</sub> emissions: 299 g/km.

The figures shown were obtained in accordance with the prescribed measuring process. They are "NEDC CO<sub>2</sub> values" pursuant to Art. 2 No. 1 Implementing Regulation (EU) 2017/1153. The fuel consumption figures were calculated on the basis of these figures. The figures are not based on an individual vehicle and do not constitute part of the product offer; they are provided solely for purposes of comparison between different vehicle models. The figures vary depending on the selected optional extras.



# A declaration of love for craftsmanship.

Anybody who has visited the city of Graz will understand our passion for craftsmanship. The place itself with its picturesque houses looks like it has been built by hand. And production of the G-Class has likewise followed this dedicated principle for almost 40 years. To this day the sheer model diversity on offer means that manual production is required. Be it the exterior or interior, many details of the new G-Class are produced lovingly and by hand. Experienced master upholsterers pay attention to every detail when making the seats. In this way, high-quality leather grades are assured the very best of attention. The upholsterers' expert eyes do not miss the slightest blemish in the leather. The result is highly exclusive collector's items fashioned by the hands of masters of their craft.



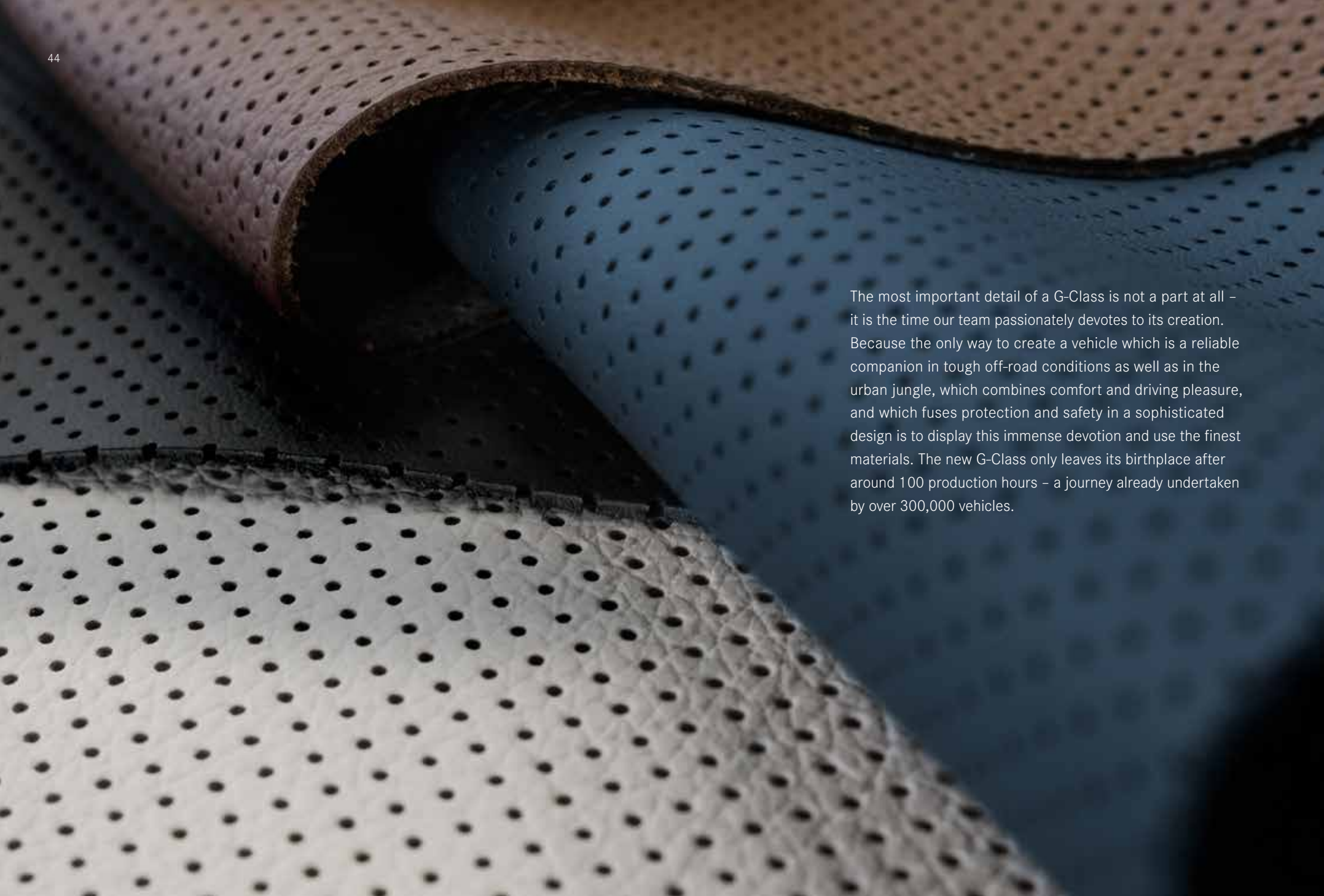

The most important detail of a G-Class is not a part at all – it is the time our team passionately devotes to its creation. Because the only way to create a vehicle which is a reliable companion in tough off-road conditions as well as in the urban jungle, which combines comfort and driving pleasure, and which fuses protection and safety in a sophisticated design is to display this immense devotion and use the finest materials. The new G-Class only leaves its birthplace after around 100 production hours – a journey already undertaken by over 300,000 vehicles.





## G for Graz.

The development of a legend is not simply a job. It's a calling. For almost 40 years, our employees have identified with the G-Class. And for almost 40 years, they have done this with unerring precision and passion. It fills them with pride that each and every G-Class first sees the light of day at the factory in Graz. At the same time, there is a responsibility which our team gladly assumes day after day. This is the only way to fill the legend of the G with life.





# From prototype to phenomenon.

It started with a vision: how do you build the perfect cross-country vehicle? What followed were numerous development steps charged with passion and devotion, characterised by a love of detail and a degree of care that can be felt in each G to this day. All combined with the desire to experience the joy we feel in building the G-Class again on every subsequent journey in it. Be it on the off-road trails of the Earth or the world's most splendid boulevards.

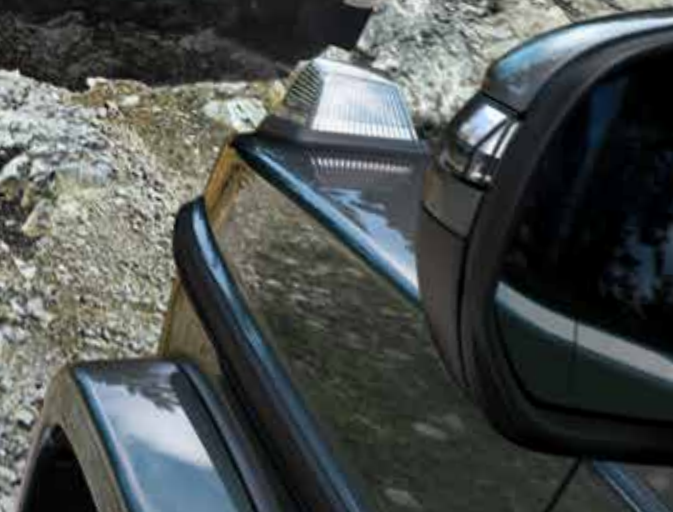

# Legends never die. This is where they are born.

Mist encircles the mountaintop. A muffled rumble issues forth from the gloom. Suddenly the G-Class forges ahead. Overcoming swathes of scree, ploughing almost impassively through the terrain. Here on the Schöckl, Graz's local mountain, the off-road abilities of the G-Class are truly put to the test. Only those that pass this severe examination earn the "Schöckl" badge as a symbol of ultimate off-road performance. However, the new G-Class also needs to impress with its ride comfort and ease of operation over long distances on the road. Only then has it proven that it is up to the job – both as an uncompromising off-roader and as an effortlessly superior on-roader.

# Some things never change.

The unique DNA of the G-Class was created around 40 years ago. Iconic features which, now as then, perform specific functions and lend the G-Class its unique appearance. They can also be found in or on the new G-Class: the distinctive door handles and the characteristic closing noise, the robust exterior protective strip, the exposed spare wheel on the tailgate, the striking turn indicators, and the grab handle for the front passenger which is so indispensable when negotiating off-road terrain. These exceptional details combine with the chiselled silhouette to lend the off-roader its unique look. They are what makes every G-Class a G-Class.

STATION-WAGEN  
DRAWING V.02

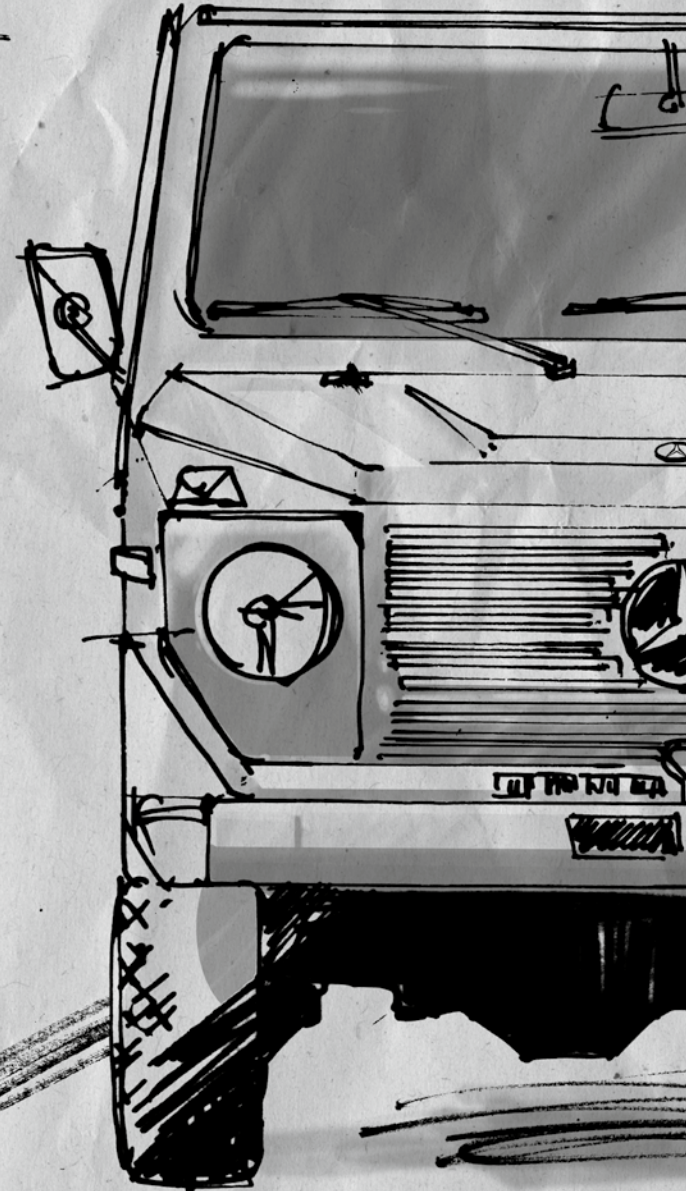

CLIMBING SLOPE  
ABILITY: > 80%



MULTI TERRAIN TYRES

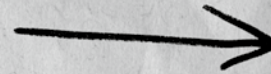

→ GRIP ←



# Rolling milestones.

The evolution of a legend.



1979

A legend is born: the “G” in the model designations for the 460 series is derived from the first letter of the German word “Geländewagen”, which means “cross-country vehicle” or “off-roader”, but it could just as well stand for Graz as this is where the G-Class has been produced by hand since the beginning. It was based on a solid ladder frame with coil-spring rigid axles and at launch offered a choice of four engines, two wheelbase lengths, and five body variants. The model line-up ranged from the 240 GD to the 300 GD and from the 230 G to the 280 GE with outputs between 53 kW (72 hp) and 115 kW (156 hp).



1980

Our very own popemobile: to mark the visit of Pope John Paul II to Germany in November 1980, Mercedes-Benz developed a unique “popemobile” based on the 230 G cross-country vehicle. It featured a large plexiglass dome to afford all the faithful a great view of the pontiff. In 2007, Pope Benedict XVI appeared in a G 500 painted in mystic white during his Wednesday audiences at St. Peter’s Square. The open body and the folding windscreen allowed close contact between pilgrims and pontiff.





1983

The winning gene in action: in their 280 GE – the top-of-the range cross-country vehicle of the time – rally drivers Jacky Ickx and Claude Brasseur defied the treacherous desert sand of the Sahara and all their competitors in the race to win the passenger-car classification in the legendary Paris-Dakar desert rally. For the gruelling long-distance rally, the body of the 280 GE was optimised in the wind tunnel and also equipped with selected aluminium components to make it lighter than the standard-production model.



1989

Happy birthday: by the time of its tenth birthday, the off-roader had met customer demands for enhanced comfort and luxurious appointments. In the thoroughly revised 463 series, the G now featured a refined interior, more comfort-oriented suspension, and permanent all-wheel drive, all of which greatly enhanced on-road handling. In the Cabriolet version, too.





1999

A strong connection: in 1999, Mercedes-Benz fused two unique strands of DNA which were actually natural bedfellows anyway – the G-Class and AMG. Since then the AMG versions of the cross-country vehicle have been winning more and more fans. So much so that they are now the most popular of the G versions. The G 55 AMG, the first G model in AMG guise, had a V8 naturally aspirated engine with an output of 260 kW (354 hp). In 2004, this first exclusive AMG model was followed by an uprated variant with a supercharged engine.



2012

The family tree grows: the G-Class received an all-new interior following an extensive facelift. The dashboard and the fully revised centre console marked a turning point in the interior design, with the focus now more firmly on ergonomics. There were also a few obvious exterior changes, although these didn't alter the character of the G-Class: new exterior mirrors and the LED daytime running lamps, for instance, enhanced road safety and made the G an ultra-modern legend.







2013

New addition to the G-Class family: an exceptional model was added to the line-up. The G 63 AMG 6x6 made the G-Class king of the desert. It marked the start of a series of spectacular G-Class special models such as the G 500 4x4<sup>2</sup> and the Mercedes-Maybach G 650 Landaulet. All of these models added further unique facets to the G-Class range and continually enhanced the fascination of the off-road legend.



2018

The evolution continues: longer, faster, wider. The new G-Class offers tangible improvements across the board. The new space concept coupled with the angular, elegant interior design enhances ride comfort considerably. The suspension, new to the G, lends the evergreen a vastly superior driving feel on the road. In off-road terrain, on the other hand, the new G-Class impresses with effortlessly superior handling on any surface. As ever, the exterior alone impresses with its characteristic design. Inside, however, there is a whole new world waiting to be discovered.







## Backbone.

Stamina means everything in tough terrain. Here there's no room for buckling or retreating. Here it's all about character. And strength of character shines through in the vehicle's backbone. In the case of the G-Class, this has always been the exceptionally robust ladder frame. Made from sheet steel up to 3.4 mm thick, the ladder frame is much more suitable for tough off-road use than a self-supporting body. In addition to this, the decoupling of the noise from the suspension and the road reduces the interior noise level and thus enhances the ride comfort.

# Full concentration ahead.

Powerful though the new G-Class is, it only ever uses its enormous power where it is needed: when negotiating off-road terrain, for example, there may only be one wheel which has traction. In this case, the three locks on the centre, rear-axle and front-axle differentials ensure that the drive torque is directed to precisely where it is required. Power paired with efficiency – the right way to get ahead.





## Overcomes obstacles at the push of a button.

Even the toughest of conditions pose little problem to the new G-Class. The low-range gearbox adjusts the shift ranges of the 9G-TRONIC transmission to driving in off-road terrain and on uphill gradients. Pressing the LOW RANGE button in the centre console increases the torque at the wheels. As a result, negotiating very difficult off-road terrain, moving off on extreme uphill gradients as well as driving downhill are all possible with significantly enhanced braking performance.



## More statics for more dynamics.

Trust is good, control is better. The new axle architecture ensures that this is the case. Demanding terrain calls for high ground clearance and outstanding traction. Both are assured thanks to the precise independent front suspension and the robustness of the rigid axle at the rear. This design enables the permanent all-wheel drive to deliver its full power and manoeuvre the G through the terrain with purpose. With its high links, the new independent suspension provides maximum ground clearance. On the road, too, the new axle architecture delivers tangibly enhanced performance, making the new G-Class an impressive proposition with its better controllability and more precise wheel location. Furthermore, the off-roader is lighter, which further improves its handling.

# As imperious on the road as it is off it.

The world has been conquered. Now it's time for the road. The new G-Class is also predestined for this. Standard equipment for the new G-Class includes AGILITY CONTROL suspension with a selective, passive damping system. The optional suspension with adaptive adjustable damping enhances the ride comfort and the perceptible driving sensation both on and off the road. The dampers adapt in line with the applied force, optimising the chassis and suspension set-up in any given situation. The roll and pitch stabilisation varies the damping characteristics continually and reduces body movement automatically. Furthermore, the new Direct-Steer system offers the driver a markedly more direct steering ratio. In addition to this, both vehicle handling and agility have been enhanced considerably. The steering effort is adjusted electronically depending on the speed and the selected driving mode. This set-up enables the driver to experience optimum response and steering characteristics at any speed as well as increasing both ride comfort and driving feel – be it in the rush hour or in the solitude of nature.

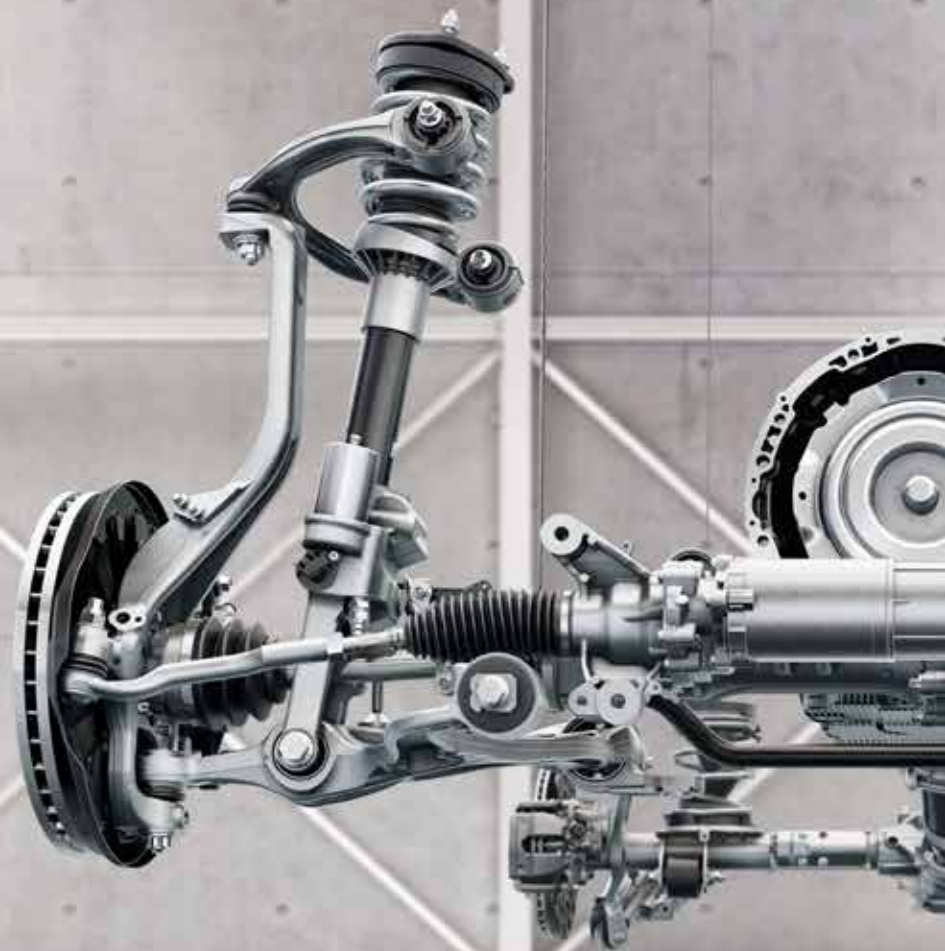





# When forces of nature come together.

## G 500

Perhaps the finest moment of all in a G 500 is the instant just before starting the engine. The anticipation of what is to come: a bombastic sound of an intensity which embraces the entire G-Class and its immediate surroundings. The off-roader impresses with its immense output of 310 kW (422 hp) coupled with extremely low levels of noise and vibration as well as outstanding agility. But the new G 500 can also glide along serenely. Cylinder shut-off makes the G a gentle giant, turning it into an efficient cruiser.

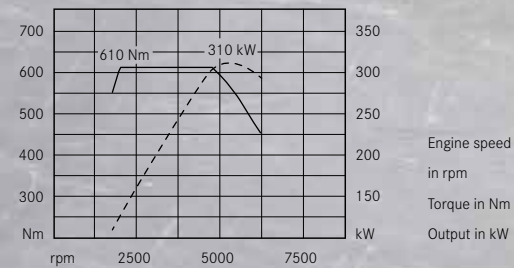

G 500 urban/extra-urban/combined fuel consumption: 14.1/10.8/12.1 l/100 km, combined CO<sub>2</sub> emissions: 276 g/km.

The figures shown were obtained in accordance with the prescribed measuring process. They are "NEDC CO<sub>2</sub> values" pursuant to Art. 2 No. 1 Implementing Regulation (EU) 2017/1153. The fuel consumption figures were calculated on the basis of these figures. The figures are not based on an individual vehicle and do not constitute part of the product offer; they are provided solely for purposes of comparison between different vehicle models. The figures vary depending on the selected optional extras.



## Power squared. The new G 500.

Unwavering, unrelenting, uncompromising. That is the G 500. It goes its own way, seemingly unbothered by the mainstream. Otherwise it would not be the idol it has become. Equipped with a brutish V8 biturbo engine, the new G 500 is a beacon of strength from the outset. Assuming a leadership role wherever it goes. An alpha leader which marks its territory vociferously.

### EXTERIOR HIGHLIGHTS

---

45.7 cm (18-inch) 5-twin-spoke light-alloy wheels, painted in a silver colour

---

3-louvre radiator trim, painted in the body colour

---

Metallic paintwork

---

LED High Performance headlamps

---

LED tail lights and turn indicators

---

"V8" lettering on the side

---

### INTERIOR HIGHLIGHTS

---

Leather upholstery

---

Open-pore natural walnut wood trim

---

Aluminium trim strip on dashboard

---

Upper section of dashboard in ARTICO man-made leather

---

Multifunction sports steering wheel with Touch Control buttons

---

Ambient lighting, with eight colour schemes to choose from

---

Double cup holder in the front centre console

---

Folding rear seat backrests with 1/3-to-2/3 split, folding rear armrest with double cup holder, armrest with through-loading feature

---





## The crowning glory of our creation. The new Mercedes-AMG G 63.

The new Mercedes-AMG G 63 does not tolerate rivals. Driven by the powerful AMG 4.0-litre V8 biturbo engine, the new Mercedes-AMG G 63 solicits full attention. The AMG-specific radiator trim and the flared wheel arches exude power.

### EXTERIOR HIGHLIGHTS

50.8 cm (20-inch) AMG 10-spoke light-alloy wheels, painted in titanium grey with a high-shine finish

AMG design, consisting of AMG front apron with black cooling air intakes, AMG-specific radiator trim, AMG-specific trim on the front and rear aprons, flared wheel arches painted in the body colour, and exterior protective strip with trim insert in black with "AMG" lettering

AMG performance exhaust system with two chrome-plated twin tailpipe trim elements on each side

AMG brake callipers, painted in red

Metallic paintwork

Stainless Steel package

LED High Performance headlamps as well as LED tail lights and turn indicators

"V8 BITURBO" lettering on the side

### INTERIOR HIGHLIGHTS

Upholstery in AMG nappa leather

AMG performance steering wheel in black nappa leather

Trim in designo black piano lacquer

Exclusive interior

AMG illuminated door sills in stainless steel





## Stainless Steel package.

Nothing combines forbidding nature and tasteful luxury as sublimely as the new G-Class. So what better way to adorn this off-road jewel than stainless steel? The Stainless Steel package consists of high-quality side running boards, a spare wheel cover in stainless steel, illuminated door sill panels in stainless steel, a rear sill protector in stainless steel, and an exterior protective strip with trim insert in black with a striped finish – lending the G more than a touch of exclusivity.



### FEATURES AT A GLANCE

---

Stainless-steel spare wheel cover with 3D Mercedes star

---

Side running boards

---

4 illuminated door sill panels in stainless steel; G 500 has “Mercedes-Benz” lettering at the front, while Mercedes-AMG G 63 has “AMG” lettering at the front and rear

---

Exterior protective strip with trim insert in black, with a striped finish

---

Rear sill protector in stainless steel, grooved

---

## AMG Line.

Sportiness with corners and edges – the AMG Line for the new G-Class. Consisting of AMG light-alloy wheels with a high-sheen finish, exterior protective strip with inserts in brushed aluminium finish, and flared wheel arches, the icon makes no secret of its sportiness. Sporty elegance abounds in the interior, too, on account of the steering wheel, AMG floor mats and red highlights. The dynamic look is rounded off by the sports exhaust system and two additional trim elements in high-gloss chrome on both the front and rear bumper.

### FEATURES AT A GLANCE

---

Hallmark AMG design, consisting of high-gloss chrome trim in front and rear apron

---

50.8 cm (20-inch) AMG multi-spoke light-alloy wheels, painted in titanium grey with a high-sheen finish; optional: painted in black with a high-sheen finish

---

AMG flared wheel arches

---

Perforated front brake discs

---

Front brake callipers with “Mercedes-Benz” lettering on the badge

---

Exterior protective strip with trim insert in a brushed aluminium finish

---

Sports exhaust system

---

3-spoke multifunction sports steering wheel in nappa leather, with flattened bottom section, heavily embossed in the grip area, with Touch Control buttons

---

Red contrasting topstitching and red belts in conjunction with leather or nappa leather in black

---

AMG floor mats with “AMG” lettering

---





## Night package.

A timeless classic like the G-Class bridges the gap between day and night. Not least thanks to the spectacular design of the Night package, which is based on the AMG Line. A wealth of black design features creates an impressive contrast with the vehicle's appearance and lends the exterior a sporty, expressive character. Large wheels featuring an exclusive design as well as darkened headlamps, turn indicators and tail lights further underline the sportiness of the equipment package. By night just as by day.



### FEATURES AT A GLANCE

---

50.8 cm (20-inch) AMG multi-spoke light-alloy wheels, painted in black with a high-shine finish

---

Spare wheel ring, exterior mirror housings, radiator trim louvres and Mercedes star surround painted in obsidian black

---

Exterior protective strip with trim insert in black, with pinstripe finish

---

Darkened headlamps, turn indicators and tail lights

---

Heat-insulating dark-tinted glass

---

Front and rear bumper trim painted in obsidian black

---



# AMG Night package.

There's a reason why most predators come out at night. Boasting an array of black design features, such as dark tinted windows and darkened headlamps, the AMG Night package adds sporty contrasts to the vehicle's exterior design. The large, black wheels in an exclusive design underline the sporty, expressive character and give the new Mercedes-AMG G 63 a real air of authority. And not just by night.



### FEATURES AT A GLANCE

- 53.3 cm (21-inch) AMG twin-spoke light-alloy wheels, painted in matt black with high-sheen rim flange; optional: 55.9 cm (22-inch) AMG cross-spoke forged wheels, painted in matt black with high-sheen rim flange
- Spare wheel ring and exterior mirror housings painted in obsidian black
- Underguard painted in obsidian black
- Exterior protective strip with trim insert in black with "AMG" lettering
- Darkened headlamps, turn indicators and tail lights
- Heat-insulating dark-tinted glass
- Front and rear bumper trim painted in obsidian black





## Active Multicontour Seat package.

People have always sought relaxation in nature. And now it's possible in an urban environment, too – thanks to the active multicontour seats with dynamic and massage functions for the driver and front passenger. Inflatable air chambers and lumbar support ensure optimum seating comfort and outstanding lateral support. In addition to this, eight massage programs enhance the feeling of well-being and turn every trip into a unique and enjoyable experience.

### FEATURES AT A GLANCE

---

Active multicontour front seats with dynamic function and massage function

---

Electrically adjustable lumbar support

---

Massage function with 14 air chambers in the seat backrest

---

Massage function with four air chambers in the seat cushion

---

Massage heating panels in the spinal area

---

Fast-acting seat heating Plus

---

Climatised seats

---

# Exclusive interior.

The classic off-roader gets to places that remain hidden for many. The new G-Class has the drive to do things which others never experience. This claim to uniqueness is also reflected in the Exclusive interior of the new G-Class. The individual appointments include the leather-trimmed dashboard, exclusive colour variations, extended contrasting topstitching, and high-grade nappa leather in the interior. The harmonious overall image underscores the exclusive character of the interior and transforms each trip in the new G-Class into a unique experience.

## FEATURES AT A GLANCE

- Seat covers and door centre panels incl. tailgate in nappa leather in black, saddle brown, truffle brown or macchiato beige
- Seat covers in Mercedes-AMG G 63 with AMG-specific design in AMG nappa leather
- Dashboard, door centre panels and grab handle for front passenger trimmed in leather with extended seam
- Armrest in black nappa leather
- designo roof liner in black DINAMICA microfibre
- Velour floor mats with edging in nappa leather in the seat colour
- AMG velour floor mats with edging in imitation nubuck leather with embroidered "AMG" lettering in the Mercedes-AMG G 63
- Frameless interior mirror
- Air vents in Silvershadow





A detailed view of the interior of a Mercedes-Benz G-Class vehicle. The image shows the driver's side, including the steering wheel with the Mercedes-Benz logo, the dashboard, and the center console. The seats are upholstered in dark brown leather with a prominent diamond-quilted pattern. The door panel also features this quilted design. The overall aesthetic is one of luxury and ruggedness, characteristic of the G-Class.

# designo manufaktur.

The G-Class has known routes which remain hidden to others from the outset. This individuality is reflected in the designo manufaktur philosophy in particular. The design gene is particularly prominent in the DNA of the G-Class. Because the new G-Class is as confidently stylish at scaling design heights as it is effortlessly superior in handling off-road terrain. Equipment variants exclusively for the new G-Class, in which everything is perfectly matched and tailored to the highest level. Perfect craftsmanship, unique style – or, to put it another way, designo manufaktur.

## Exclusive interior.

Those used to scaling summits also try to excel themselves when it comes to design. designo manufaktur enables further individualisation of the Exclusive interior with seats in two-tone designo nappa leather<sup>1</sup> in platinum white/black, classic red/black, or yacht blue/black. These sporty, elegant interior appointments are rounded off with coordinated contrasting topstitching in white, red or blue on the dashboard, door centre panels, seat side bolsters, head restraints, and front armrest.

<sup>1</sup> Mercedes-AMG G 63 has two-tone AMG Exclusive nappa leather.

## Exclusive Plus interior.

High-quality craftsmanship for even more individuality: the Exclusive Plus interior. The stylish designo manufaktur appointments afford the interior an even more luxurious atmosphere. The highest-quality nappa leather is used from the dashboard and seats through to the doors. The thrilling interior includes appointments imbued in macchiato beige/espresso brown. A further design highlight is the diamond design on the seats, the door centre panels including tailgate, and the sides of the centre console.

### FEATURES AT A GLANCE

Seats in designo nappa leather<sup>1</sup> in macchiato beige, espresso brown, classic red or black with diamond stitching, perforated upholstery and colour-coordinated topstitching

"designo" metal badge<sup>2</sup> in the front backrests

Door panels, door armrests, armrest and upper centre console trim as well as dashboard (upper and lower section) in nappa leather

Door centre panels incl. tailgate and kneepads on the sides of the centre console in nappa leather with diamond stitching

designo velour floor mats in black or espresso brown with edging in designo nappa leather incl. "designo" metal badges<sup>3</sup>

designo roof liner in DINAMICA microfibre in black or macchiato beige

Frameless interior mirror

Air vents in Silvershadow

<sup>1</sup> Mercedes-AMG G 63 AMG has seats in AMG Exclusive nappa leather. <sup>2</sup> Mercedes-AMG G 63 has "AMG" metal badge.

<sup>3</sup> Mercedes-AMG G 63 AMG has velour floor mats with edging in imitation nubuck leather and embroidered "AMG" lettering.



## Leave everything behind you.

For all those who love the practical side of things: the EASY-PACK load compartment cover protects luggage from the sun and prying eyes in equal measure. The dividing net creates a barrier between the vehicle occupants and non-secured items in the load compartment. The trailer coupling with ball head has been tested by Mercedes-Benz and ensures that the frame optimally absorbs the tractive forces exerted by the trailer. If the trailer starts to sway, the standard-fit ESP® with trailer stabilisation applies a specific brake force to the wheels, helping the driver to keep the vehicle/trailer combination on track and to guide it safely through the traffic.

### OPTIONAL EXTRAS AT A GLANCE

---

Trailer coupling with ESP® trailer stabilisation

---

EASY-PACK load compartment cover

---

Dividing net

---



## Natural protection.

Things can get quite frantic in off-road terrain. The G-Glass is prone to a certain risk of damage caused by flying stones. The anti-spray mudflaps at the front and rear therefore also protect against stone damage in the side flank, underfloor and rear areas. All-terrain tyres developed specifically for the new G-Class, which are as robust and resistant as the G-Class as a whole, are the icing on the cake in terms of off-road features. They enable the driver to negotiate even the toughest of terrain. And the 360° camera with off-road view allows the driver to keep an eye on all of this.

### OPTIONAL EXTRAS AT A GLANCE

---

45.7 cm (18-inch) 5-spoke light-alloy wheels, painted in matt black with all-terrain tyres

---

Front and rear mudflaps

---

Parking package with 360° camera, including Front View with off-road view

---





## Always one situation ahead.

With Intelligent Drive, Mercedes-Benz has reached an important milestone on the road to autonomous driving. Numerous intelligent assistance systems take a lot of the strain off the driver and thus enhance safety significantly for all road users. Away from off-road terrain, **Active Lane Keeping Assist** can detect when the car leaves its lane unintentionally, warn the driver by making the steering wheel vibrate, and actuate the brakes on one side to help manoeuvre the vehicle back into its lane. Meanwhile, the **PRE-SAFE® system** is able to identify critical driving situations in advance and to initiate precautionary measures to protect the vehicle's occupants if an accident appears imminent. Such measures include reversible belt tensioning or automatic closing of open side windows, for example.

Thanks to **DYNAMIC SELECT** drivers have an option for choosing between comfortable, sporty, efficient or individually defined driving characteristics at their fingertips. Parameters such as the drive system including exhaust flaps, steering, start/stop function, ESP®, assistance systems and the optional suspension with adaptive adjustable damping can be adjusted automatically, depending on the selected driving mode. All for even better on-road performance.

### OTHER SAFETY AND ASSISTANCE SYSTEMS AT A GLANCE

---

The **Active Brake Assist** gives the driver a visual warning if the distance to the vehicle in front is too small. An audible warning sounds when a danger of collision is identified; it can also provide braking assistance in line with the situation at hand and, if the driver fails to react, initiate autonomous braking.

---

The **Traffic Sign Assist** system is able to recognise speed limits, no-entry and no-overtaking signs and their cancellation, and display them to the driver. If the vehicle enters a road against the allowed direction of travel, a visual and acoustic warning is emitted when appropriate traffic signs are detected.

---

During long and monotonous trips, e.g. on motorways or main roads, **ATTENTION ASSIST** can detect typical signs of drowsiness or increasing inattention on the part of the driver at speeds between around 60 and 200 km/h. The driver then receives an appropriate warning and is prompted to take a break, thus enhancing road safety.

---

The optional **Driving Assistance package** includes Active Distance Assist DISTRONIC as well as Blind Spot Assist. This combination makes life easier for the driver when driving in convoy on motorways and main roads as well as in stop-and-go traffic, and it can enhance safety by monitoring the vehicle's blind spot.

---

## Park like a compact car.

When driving off-road, the new G-Class parks where it wants. In the city, there are two optional equipment packages which can assist with parking. The **Parking package with reversing camera** makes it easier to both find a parking space and to enter and leave parallel or end-on parking spaces. It consists of a reversing camera and Active Parking Assist with PARKTRONIC. The **Parking package with 360° camera**, meanwhile, allows parking and manoeuvring with a realistic all-round view provided by four networked cameras and even gets the new G-Class into tight spaces with ease. A separate off-road view shows the immediate surroundings ahead of the vehicle – a big help when driving in poorly visible terrain.





## Connects you from A to B.

The new G-Class does not just connect you to the world. It is also connected to the world itself. Thanks to **COMAND Online**, there is practically nothing left to be desired where infotainment, navigation and communications are concerned. Information is shown on the 31.2 cm (12.3-inch) high-resolution display of the multimedia system. The hard-disc navigation provides quick guidance to even remote destinations with the aid of Live Traffic Information<sup>1</sup>. In addition to this, the Car-to-X communication can warn the driver of dangers in advance. This involves the exchange of important information between vehicles, such as dangerous situations already detected by other vehicles. What's more, the optional **Burmester® surround sound system** with 590 watts and 15 loudspeakers provides the appropriate soundtrack for any trip.

<sup>1</sup> Free of charge for three months; total free term of three years only available if the user opens a Mercedes me user account and accepts the general and special Terms Of Use.

## INFOTAINMENT AND MULTIMEDIA

**Smartphone Integration** enables the integration of compatible smartphones with appropriate operating system into the vehicle via Apple CarPlay™ and Android Auto. These devices can then be operated by voice control, for example. This makes safe use possible while on the move. The system supports the most important programs and selected apps including navigation.

Optional extras include the new **Car Telephony** with SIM card reader. Car Telephony allows the connection of a mobile phone using the Bluetooth® protocol SAP (SIM Access Profile) or direct operation by inserting a SIM card into the integral SIM card reader. Use of the exterior aerial ensures optimum reception.

The optional **digital radio** offers interference-free sound in CD quality via DAB (incl. DAB+ and DMB) and programme-accompanying additional information, e.g. cover, weather maps, news and traffic jam maps. In the background three DAB tuners always ensure optimum reception quality of the station selected.

Television with a wide selection of stations in excellent quality – the optional **TV tuner** also makes this possible in a vehicle. It supports the reception of digital channels compliant with the DVB-T and DVB-T2 standards, as well as the reception of encrypted channels courtesy of a CA slot allowing the installation of corresponding CI+ modules. Reproduction is in near-DVD quality and in stereo. Furthermore, a wide variety of additional information can also be accessed, e.g. electronic TV magazines or videotext.

The optional **Widescreen Cockpit** supplements the 31.2 cm (12.3-inch) display of the multimedia system with a high-resolution 31.2 cm (12.3-inch) instrument display featuring three selectable display styles under a shared glass cover.





## Genuine accessories.

What can you give a vehicle that already has it all? The perfect genuine accessories. Design your new G-Class just how you want and imagine it with everything that makes driving even more pleasurable. The full range can be found at [www.mercedes-benz-accessories.com](http://www.mercedes-benz-accessories.com)

### HIGHLIGHTS

The **basic carrier bars** are designed specifically for the body of your new G-Class and form the basis for a wealth of Mercedes-Benz transport solutions: ski and snowboard racks, bike racks or roof boxes. They are available in an aerodynamic, noise-optimised Mercedes-Benz design, have been crash-tested, and are lockable.

Adapted exclusively for your Mercedes-Benz, the **Mercedes-Benz roof box 450** featuring an aerodynamic design and made from extremely durable material is ideal for fast attachment to the basic carrier bars. Thanks to the handle, it can be opened and closed easily on both sides and is therefore extremely convenient for loading and unloading. All this with a capacity of around 450 litres and a maximum payload of 75 kg.

Should you need to transport up to six pairs of skis<sup>1</sup> or four snowboards, the lockable **combined ski and snowboard rack New Alustyle Comfort** is the ideal solution. The practical pull-out function makes loading and unloading easier.

<sup>1</sup> Depending on the geometry of the skis.



---

Another extremely practical item is the **boot tub**: shallow, black, made from impact-resistant polypropylene – with anti-slip effect. And with a ribbed structure for attaching the separately available stowage box, leaving the vehicle’s load-securing rings accessible.

---

As an elegant fast-charging device for your mobile phone, the **USB Power Charger** offers a wealth of practical options. Its intelligent “Smart Charging” logic and a charging output of up to 2 x 2.4 A ensure quick and easy charging via the cigarette lighter when on the road. The elegant shape is reminiscent of your vehicle key and fits into the vehicle interior perfectly. Its overheating protection and the subtly illuminated USB slots ensure easy operation, even in the dark.

---





RK8



RK1



RK2



RK4



RM9



RK7



RK3



RG6

## Wheels.

RK8 45.7 cm (18-inch) 5-twin-spoke light-alloy wheels, painted in silver colour, with 265/60 R 18 tyres (standard for G 500; not available for AMG Line or Night package)

RM9 45.7 cm (18-inch) 5-twin-spoke light-alloy wheels, painted in silver colour, with 265/60 R 18 tyres (option for G 500; not available for AMG Line or Night package)

RK1 45.7 cm (18-inch) 5-spoke light-alloy wheels, painted in silver colour, with 265/60 R 18 tyres (option for G 500; not available for AMG Line or Night package)

RK7 45.7 cm (18-inch) 5-spoke light-alloy wheels, painted in matt black, with 265/60 R 18 all-terrain tyres (option for G 500; not available for AMG Line or Night package)

RK2 48.3 cm (19-inch) 5-twin-spoke light-alloy wheels, painted in titanium grey with a high-sheen finish, with 275/55 R 19 tyres (option for G 500; not available for AMG Line or Night package)

RK3 48.3 cm (19-inch) 8-spoke light-alloy wheels, painted in titanium grey with a high-sheen finish, with 275/55 R 19 tyres (option for G 500; not available for AMG Line or Night package)

RK4 50.8 cm (20-inch) AMG multi-spoke light-alloy wheels, painted in titanium grey with a high-sheen finish, with 275/50 R 20 tyres (part of package in conjunction with AMG Line for G 500)





RG1



RG3



RG4



RG2



RG5

RG6 50.8 cm (20-inch) AMG multi-spoke light-alloy wheels, painted in black with a high-sheen finish, with 275/50 R 20 tyres (part of package in conjunction with Night package for G 500 and option in conjunction with AMG Line)

RG1 50.8 cm (20-inch) AMG 10-spoke light-alloy wheels, painted in titanium grey with a high-sheen finish, with 275/50 R 20 tyres (standard for Mercedes-AMG G 63)

RG2 53.3 cm (21-inch) AMG 5-twin-spoke light-alloy wheels, painted in titanium grey with a high-sheen finish, with 285/45 R 21 tyres (option for Mercedes-AMG G 63)

RG3 53.3 cm (21-inch) AMG 5-twin-spoke light-alloy wheels, painted in matt black with high-sheen rim flange, with 285/45 R 21 tyres (option for Mercedes-AMG G 63 or standard in conjunction with Night package for Mercedes-AMG G 63)

RG5 55.9 cm (22-inch) AMG cross-spoke forged wheels, painted in titanium grey with a high-sheen finish, with 295/40 R 22 tyres (option for Mercedes-AMG G 63; not available for Night package)

RG4 55.9 cm (22-inch) AMG cross-spoke forged wheels, painted in matt black with high-sheen rim flange, with 295/40 R 22 tyres (option for Mercedes-AMG G 63)





Passion grows when it is shared: the AMG Private Lounge is our community focused around the world of AMG. This is where AMG customers meet at first-class events and on the online platform exchange views about the latest developments from Affalterbach. They benefit from special offers and from direct connection with the AMG headquarters:

[www.mercedes-amg.com/privatelounge/welcome](http://www.mercedes-amg.com/privatelounge/welcome)

The AMG Driving Academy stands for an incomparable team spirit: experience performance with like-minded drivers and improve your driving skills on racetrack and lifestyle events held at breathtaking locations around the world. Become a part of the “World’s Fastest Family”: [www.mercedes-amg.com/driving-academy](http://www.mercedes-amg.com/driving-academy)

Want even more? Mercedes-AMG Motorsport offers the ideal platform for professional motorsport with the Customer Racing Program – and with the Mercedes-AMG GT3 race car developed specifically for the purpose. A fully integrated service package delivers top-level racing: [www.mercedes-amg.com/customerracing](http://www.mercedes-amg.com/customerracing)

At the AMG Performance Studio, we build automobiles tailor-made to your wishes. The creativity of our experts knows no bounds – from special technical components, through extravagant paint finishes to exclusive interior appointments, this is where one-offs are fashioned, to the very highest standards of handmade craftsmanship.

Enter the world of AMG. Experience Driving Performance.

We don't just build cars.  
We make dreams come true.

## Life can be so fascinating when you're fully connected.

All our connectivity and mobility services plus a host of other fascinating features – all in one place and exclusively for you. That's Mercedes me. Register free of charge today and make the world of Mercedes-Benz your very own at your convenience – on your PC or laptop or in mobile mode via tablet, smartphone or smartwatch. And because your life is forever changing, our services are also continually evolving. Join us now at: [www.mercedes.me/welcome](http://www.mercedes.me/welcome)

Looking for individual inspiration in real life, too? The Mercedes me Stores are a fascinating phenomenon worldwide – in Beijing, Moscow and Hamburg, for example.



**Mercedes me connect** connects you with your vehicle – and your vehicle with the whole world. A comprehensive range of convenient connectivity services relating to all areas of your vehicle supports you, ensuring greater safety, closer contact and an even more fascinating driving experience. It's reassuring to stay connected all the time while you're on the move. Mercedes me connect includes Standard Services, which are able to provide you with automatic support in the event of a breakdown or an accident, as well as Remote Online Services – the option enabling vehicle settings to be carried out by smartphone – and lots more besides.

**Mercedes me inspire** offers special brand experiences and an opportunity to engage in an inspiring dialogue. We aim to share our ideas with you and we would like to know your ideas and wishes. So that we can always offer you the best solutions. A community is available to this end, and you will also find a growing range of offerings and experiences which go beyond the traditional vehicle-related topics – from areas such as events, travel and lifestyle.

**Mercedes me move** offers access to intelligent mobility solutions: car2go is the pioneer and global market leader in free-floating car sharing, the moovel mobility app pools the offerings from various mobility providers to find the ideal route from A to B. With the mytaxi app you can order a taxi, track its approach live and pay for your journey in a convenient manner. Mercedes-Benz Rent offers vehicles to suit all occasions for short- or long-term rental from an authorised Mercedes-Benz dealer near you. Blacklane enables you to book a chauffeur-driven limousine, FlixBus offers inexpensive, comfortable and environment-friendly trips on long-distance coaches.

**Mercedes me assist** makes easy work of organising maintenance for your vehicle, providing a convenient online means of locating a Mercedes-Benz dealer in your neighbourhood and arranging a service appointment. The digital service report keeps you up to date on performed service work. The report can be made available to you online just one day after a service. In addition to the current service report, you can also view your vehicle's complete service history and service intervals, and you can print this information out if you so wish.

**Mercedes me finance** offers you various routes to your vehicle of choice. Mercedes-Benz Bank/Mercedes-Benz Financial Services finds the ideal leasing, financing and insurance solution together with you – tailored to your needs. Our leasing products enable you to drive the latest models at all times while enjoying maximum flexibility, as you pay not for acquisition of the vehicle, but only for its use. You also benefit from attractive monthly instalments. Our financing arrangements enable you to pay for your new Mercedes-Benz in a way that suits your personal budget. You can tailor your monthly instalments to your needs by deciding on an appropriate down-payment and term for your contract. Our individual insurance solutions offer reliable protection for your budget and your vehicle on attractive terms. Your existing financial contracts can be managed conveniently online.<sup>1</sup>

<sup>1</sup> Depending on market availability.

# Show of strength.

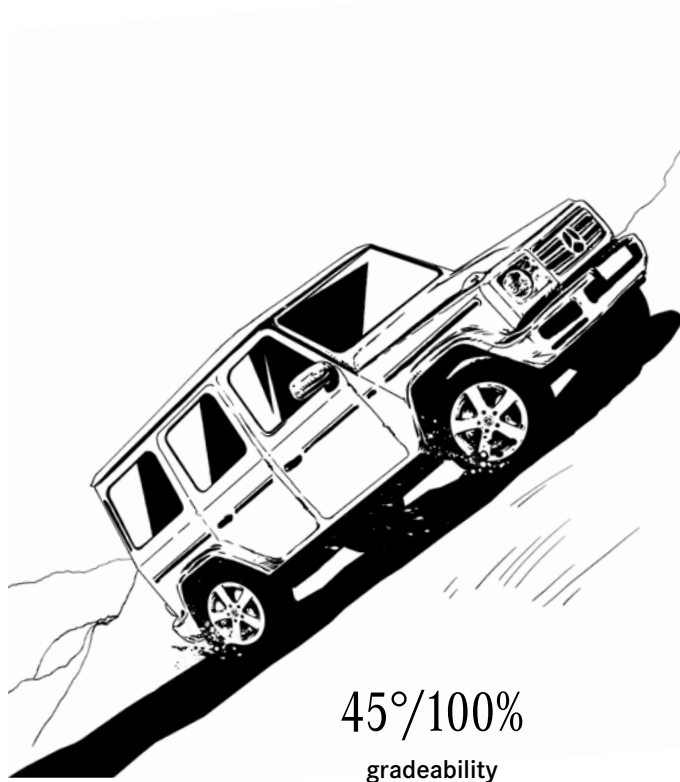

**45°/100%**  
gradeability



**29.9°**  
angle of departure

**30.9°**  
angle of approach



**241 mm**  
ground clearance

Figures are for G 500 with standard equipment in ready-to-drive condition as per EC.

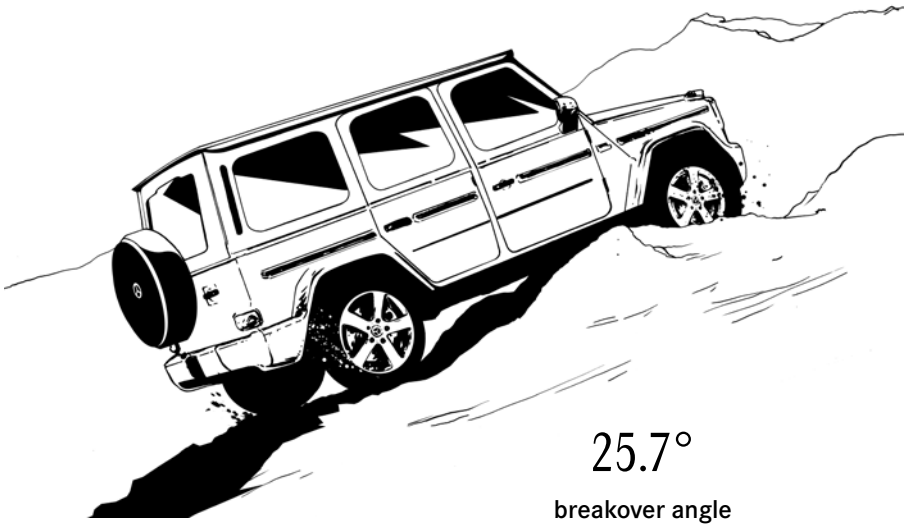

25.7°  
breakover angle



35°/70%  
inclination



700 mm  
fording depth

# The measure of greatness.

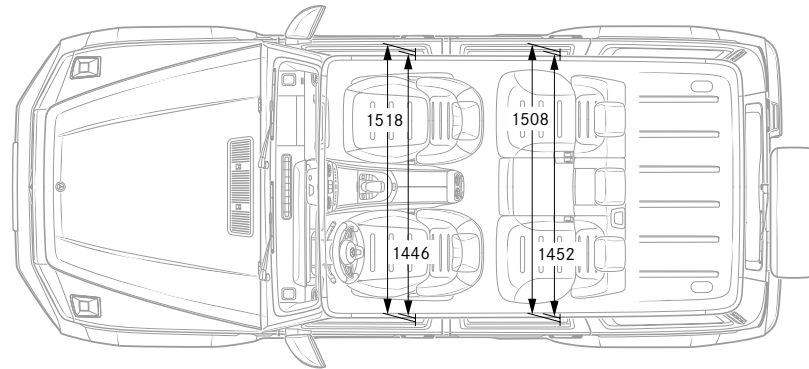
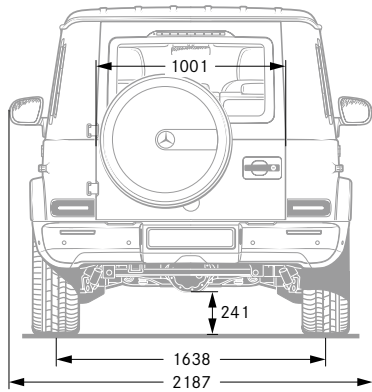
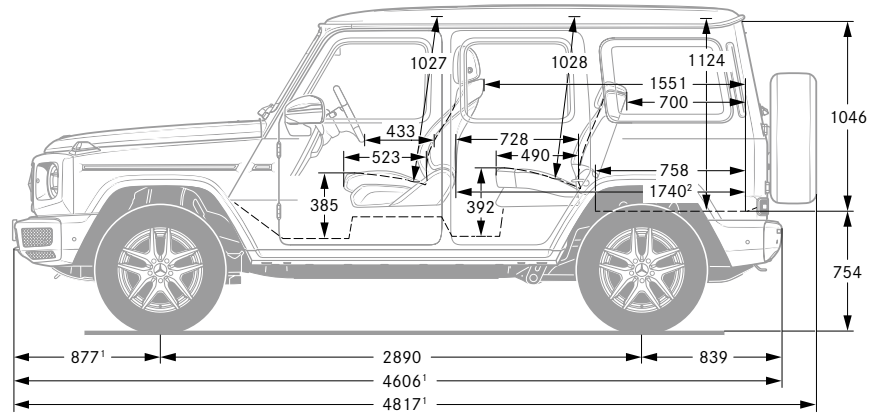
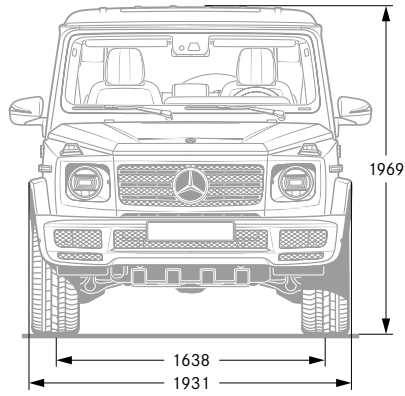

Figures for G 500.

<sup>1</sup> Without license plate adapter. <sup>2</sup> Measured at 14.4° inclination. All figures in millimetres. The dimensions shown are mean values and apply to standard-specification, ready-to-drive vehicles as per EC.



## Technical data.

	<b>G 500</b>	<b>Mercedes-AMG G 63</b>
Cylinder arrangement/number	V/8	V/8
Displacement (cc)	3982	3982
Rated output <sup>1</sup> (kW (hp) at rpm)	310 (422)/5250–5500	430 (585)/6000
Rated torque <sup>1</sup> (Nm at rpm)	610/2250–4750	850/2500–3500
Compression ratio	10.5 : 1	8.6 : 1
Transmission	9G-TRONIC	AMG SPEEDSHIFT TCT 9G
Acceleration 0–100 km/h (s)	5.9	4.5
Top speed (km/h)	210	220 <sup>6</sup>
Tyres/wheels front, rear	265/60 R 18	275/50 R 20
Fuel	Premium-grade petrol	Super Plus petrol
Fuel consumption <sup>2</sup> (l/100 km)		
Urban	14.1	16.5
Extra-urban	10.8	11.1
Combined	12.1	13.1
CO <sub>2</sub> emissions <sup>2</sup> , combined (g/km)	276	299
Emission class <sup>3</sup> /efficiency class <sup>4</sup>	Euro 6d-TEMP/E	Euro 6d-TEMP/F
Tank capacity/incl. reserve (l)	75/10.0	100/12.0
Turning circle (m)	13.6	13.5
Kerb weight <sup>5</sup> /Payload (kg)	2429/721	2560/640
Perm. GVW (kg)	3150	3200
Perm. towing capacity, braked/unbraked [at 12%] (kg)	750/3500	750/3500

**The best for the engine:**  
**Mercedes-Benz genuine engine oil.**

<sup>1</sup> Figures for rated output and rated torque according to the currently applicable version of Directive (EC) No. 595/2009. <sup>2</sup> The figures shown were obtained in accordance with the prescribed measuring process. They are "NEDC CO<sub>2</sub> values" pursuant to Art. 2 No. 1 Implementing Regulation (EU) 2017/1153. The fuel consumption figures were calculated on the basis of these figures. The figures are not based on an individual vehicle and do not constitute part of the product offer; they are provided solely for purposes of comparison between different vehicle models. The figures vary depending on the selected optional extras. <sup>3</sup> Figure only valid within the European Union. May vary from country to country. <sup>4</sup> Determined on the basis of the measured CO<sub>2</sub> emissions, taking account of the vehicle weight. The figures vary depending on the selected optional extras. <sup>5</sup> Vehicle kerb weight with fuel tank filled to at least 90% of its capacity, plus the weight of the driver (generally estimated as 75 kg for legal purposes), the fuel and the fluids, equipped with the standard equipment as indicated by the manufacturer as well as, if included, the weight of the body, the cab, the trailer coupling and the spare wheel(s) as well as the tools. Optional extras, additional equipment and accessories can influence the weight, remaining payload, rolling resistance, aerodynamics etc. and therefore the fuel consumption and CO<sub>2</sub> figures. <sup>6</sup> 240 km/h if AMG Driver's Package is included. For more technical data, please visit [www.mercedes-benz.com](http://www.mercedes-benz.com)

# Upholstery and trim.

---

## Leather

---

- 201 black<sup>2, 3, 4, 5</sup>  
 214 nut brown/black<sup>4, 5, 6</sup>  
 215 macchiato beige/black<sup>4, 5, 6</sup>
- 

## Nappa leather/AMG nappa leather<sup>1</sup>

---

- 501 black<sup>3, 5, 7, 8, 9</sup>  
 524 saddle brown/black<sup>5, 7, 8, 10</sup>  
 525 truffle brown/black<sup>5, 7, 8, 10</sup>  
 535 macchiato beige/black<sup>5, 7, 8, 10</sup>
- 

## designo two-tone nappa leather/AMG two-tone Exclusive nappa leather<sup>1</sup>

---

- 582 yacht blue/black<sup>5, 7, 8, 11</sup>  
 583 platinum white/black<sup>5, 7, 8, 11</sup>  
 587 classic red/black<sup>5, 7, 8, 11</sup>
- 

## designo nappa leather/AMG Exclusive nappa leather<sup>1</sup>

---

- 801 black<sup>4, 7, 11, 12</sup>  
 804 espresso brown/black<sup>4, 7, 11, 12</sup>  
 805 macchiato beige/espresso brown<sup>4, 7, 11, 12</sup>  
 807 classic red/black<sup>4, 7, 11, 12</sup>
- 

## Trim

---

- VA1 designo open-pore black flamed ash wood<sup>7, 11</sup>  
 VA2 Open-pore natural walnut wood<sup>2, 11</sup>  
 VA3 High-gloss brown ash wood<sup>7, 11</sup>  
 VA4 High-gloss light brown Sen wood<sup>7, 11</sup>  
 VA5 Metal structure<sup>7, 11</sup>  
 ZG2 designo black piano lacquer<sup>7, 9</sup>  
 ZG6 AMG carbon fibre<sup>7, 11</sup>
- 

## Leather



201



214

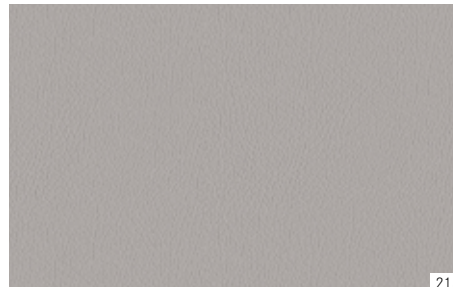

215

## Nappa leather/ AMG nappa leather<sup>1</sup>

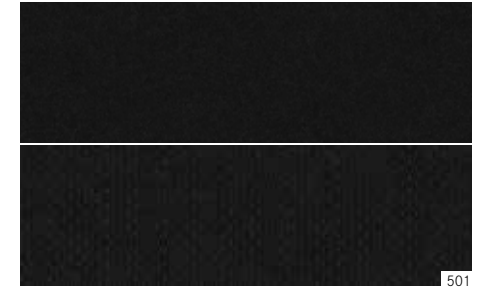

501



524

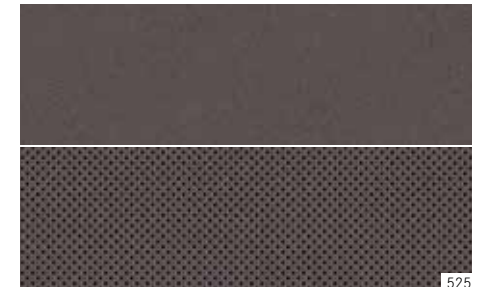

525

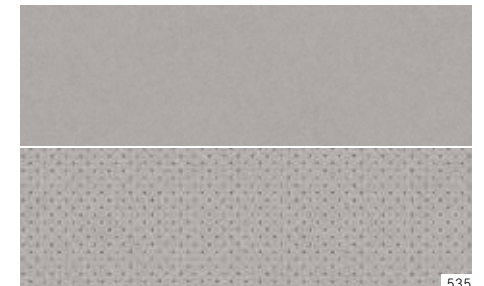

535

<sup>1</sup> Only in conjunction with Mercedes-AMG models. <sup>2</sup> Standard for G 500. <sup>3</sup> Red topstitching only available in conjunction with AMG Line.

<sup>4</sup> Not available in conjunction with Exclusive interior. <sup>5</sup> Not available in conjunction with Exclusive Plus interior. <sup>6</sup> No-cost option for G 500. <sup>7</sup> Optional extra for G 500. <sup>8</sup> Only available in conjunction with Exclusive interior. <sup>9</sup> Standard for Mercedes-AMG G 63.

<sup>10</sup> No-cost option for Mercedes-AMG G 63. <sup>11</sup> Optional extra for Mercedes-AMG G 63. <sup>12</sup> Only available in conjunction with Exclusive Plus interior.

designo two-tone nappa leather/  
AMG two-tone Exclusive nappa leather<sup>1</sup>

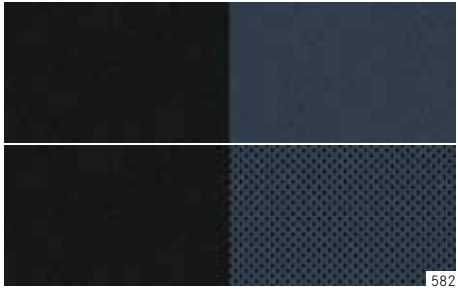

582

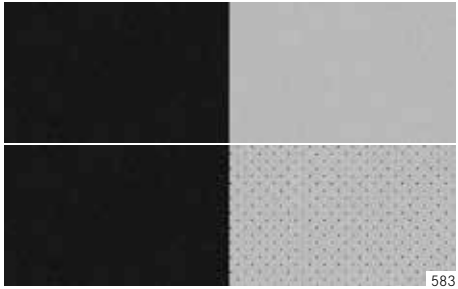

583

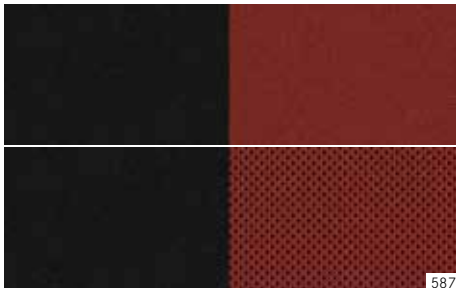

587

designo nappa leather/  
AMG Exclusive nappa leather<sup>1</sup>



801



804



805



807

Trim



VA1

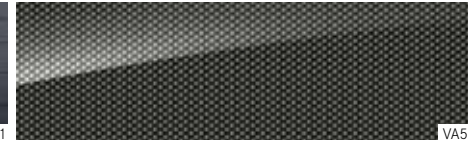

VA5



VA2



ZG2



VA3



ZG6



VA4

# Paintwork.

---

## Non-metallic paints

---

- 040 black  
149 polar white
- 

## Metallic paints

---

- 183 magnetite black  
197 obsidian black  
660 rubellite red  
775 iridium silver  
859 mojave silver  
890 cavansite blue  
896 brilliant blue  
989 emerald green  
992 selenite grey
- 

## designo manufaktur paints<sup>1</sup>

---

- 464 designo desert sand non-metallic  
026 designo ocean blue metallic  
041 designo graphite metallic  
046 designo platinum black metallic  
255 designo olive metallic  
996 designo hyacinth red metallic  
032 designo mystic blue bright  
052 designo mystic brown bright  
799 designo diamond white bright  
051 designo platinum magno  
056 designo night black magno  
271 designo citrine brown magno  
671 designo yellow olive magno
- 

### Non-metallic paints

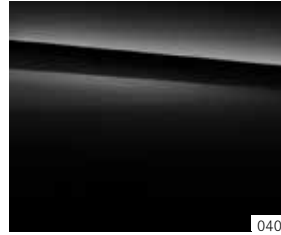

040



149

### Metallic paints

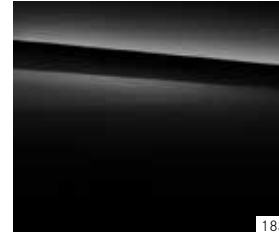

183

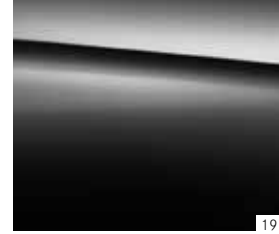

197



660



775



859



890



896



989



992

### designo manufaktur paints<sup>1</sup>



464



026

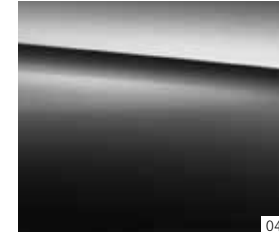

041



046



255



996

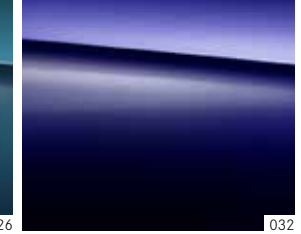

032



052



799



051

<sup>1</sup> Optional extra.

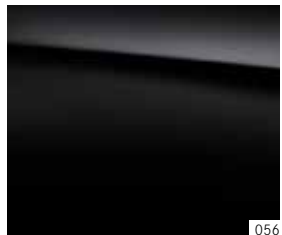

056

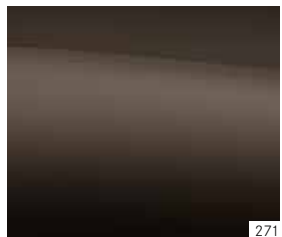

271

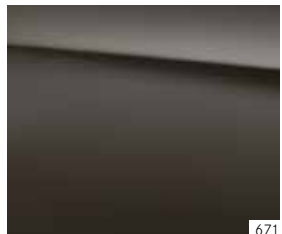

671

## Off-road traces.

When you conquer the world with the G-Class, you leave behind traces of fascination and adventure. From the desert sand in the Middle East to the deep, dark brown mud from the Mexican jungle – all of the world's off-road traces sit equally well on the G-Class.



001



005



002



006



003



007



004



008

---

### Non-metallic dirt

- 001 Dubai, Ras al-Khaimah
- 002 Australia, Ayers Rock
- 003 Iceland, Jörkulsárlón

---

### Hard mud

- 004 Austria, Schöckl
- 005 China, Yangtze Kiang

---

### Powder mud

- 006 USA, Mojave desert
  - 007 Mexico, Yucatán
  - 008 Russia, West Siberian Plain
-



# SPORT — F O R — GOOD

**Mercedes-Benz is one of the founding partners of the “Laureus Sport for Good Foundation”.**

Since the foundation was established in 2000, Mercedes-Benz has been supporting and promoting the aims and values of this worldwide non-profit-making programme: to use social sports projects to improve the lives of children and young people who are disadvantaged or suffering from illness. Laureus has become a fundamental element of Mercedes-Benz’s social responsibility. Every new Mercedes is an ambassador embodying these values. In buying a Mercedes you are supporting the “Laureus Sport for Good Foundation”.

**Please note:** changes may have been made to the product since this brochure went to print (14.02.2018). The manufacturer reserves the right to make changes to the design, form, colour and specification during the delivery period, provided these changes, while taking into account the interests of the vendor, can be deemed reasonable with respect to the purchaser. Where the vendor or the manufacturer uses symbols or numbers to describe an order or the subject of an order, no rights may be derived solely from these. The illustrations may show accessories and optional extras which

are not part of standard specification. This brochure is distributed internationally. Information on statutory, legal and fiscal provisions and their consequences apply only to the Federal Republic of Germany at the time this brochure went to print. For information on the statutory, legal and fiscal provisions and their consequences in other countries and the latest official information, please ask your Mercedes-Benz salesperson.

[www.mercedes-benz.com](http://www.mercedes-benz.com)