

The CLA Coupé



Mercedes-Benz



Everything that makes you special.

New around town and all set to make a lasting impression. The design puts a shine on you. The performance puts you in the fast lane. The interface speaks your language. That's your CLA Coupé.





A man with a large afro hairstyle, wearing a red and white striped short-sleeved shirt, is leaning against the open driver-side door of a white sports car. The scene is set at night with dramatic, low-key lighting in shades of red and blue. The car's sleek design, including its frameless door and side mirror, is highlighted by the ambient light. The man has a serious, self-assured expression.

Strikingly self-assured.

Progressive dynamism from the bonnet to the rear. The sloping front end hints at a forceful personality. Frameless doors underscore the unfettered coupé character. Its muscular shoulders and broad rear turn heads.

鮨

カラオケ館

消火栓

カラオケ館

新橋正・誠
スプレース

年無
中休



The image shows the interior of a Mercedes-Benz CLA Coupé. The view is from the driver's perspective, looking towards the steering wheel and the panoramic sunroof. The sunroof is open, revealing a starry night sky with a prominent red nebula. The car's interior is illuminated with a soft, ambient glow, primarily in shades of blue and red. The steering wheel features the Mercedes-Benz logo in the center and various control buttons. The dashboard and instrument cluster are visible, showing a digital display with a speedometer and other vehicle information. The overall atmosphere is futuristic and luxurious.

Nice to meet you.

Welcome to MBUX (Mercedes-Benz User Experience). Now you can communicate with the CLA Coupé as you would with a friend. It's all done with natural language, by touch or with intuitive gestures – and even in augmented reality. With the help of artificial intelligence, the system can learn from you, advise you and remember your preferences.



Home | Map | Search | 4G LTE | 22:00

Mercedes me & Apps Comfort Media Bluetooth

20.0°C 20.0°C

AUTO 120 100 80 60 40 20 0

When it comes to safety, the CLA is suddenly very down to earth.

All together and all for you. The Driving Assistance packages combine the assistance systems with the safety systems. This means that hazards can be recognised in good time, warnings displayed and, in an emergency, braking manoeuvres initiated.





The image shows the interior of a Mercedes-Benz CLA Coupé. The seats are upholstered in a combination of black and white leather with blue accents. The dashboard and center console are black with silver trim. The ambient lighting is a vibrant blue, creating a modern and luxurious atmosphere. The steering wheel is black with silver accents and features the Mercedes-Benz logo. The overall design is sleek and contemporary.

Ready to feel perfectly at home?

The displays in the Mercedes-Benz CLA Coupé are designed for your wellbeing. Everything can be set up the way you want to see it. The pleasant wrap-around design with ambient lighting ensures flowing transitions. Luxury that you can feel comes courtesy of the heated steering wheel and the state-of-the-art Widescreen Cockpit with touchscreen.

A blurred night street scene with neon signs and a red car in the foreground. The scene is captured with a long exposure, creating motion blur in the background. The neon signs are in various colors, including red, blue, and yellow. The red car is in the foreground, partially visible on the right side. The overall atmosphere is vibrant and dynamic.

Sport needs rules. Play by your own.

You decide on the set-up with the controls at your fingertips. Even the shock absorbers are adjustable to your wishes. The dynamic coupé lines, incidentally, don't only look magnificent, but also offer extremely little resistance to the wind. This reduces fuel consumption and noise, while also enhancing driving stability.





ENERGIZING packages.

Fitter and in better form at the end of your journey than when you set off? This happens not by magic, but courtesy of the ingenious ENERGIZING packages. Depending on the selected equipment, different comfort systems are combined to create precisely defined programs. Light mood, music and optional massage seats, for example. The driver can select the different programs conveniently via touch control.



Fully digital Widescreen Cockpit.

The so-called Widescreen Cockpit consists of two HD displays behind one continuous glass panel. The media display on the right is a touchscreen that shows all infotainment content and vehicle settings. On the left is the traditional instrument cluster. Although, in actual fact, the name is the only traditional thing about it. Various display styles provide full scope for individual configuration.



Head-up display.

The driver's undivided attention remains on the road and the current traffic conditions, because the head-up display projects key information in front of the windscreen. This is less tiring on the eyes, as they are not constantly having to switch between near and far.



Smartphone Connectivity package.

This package links your smartphone to your vehicle's controls and displays. As a result you can use your smartphone content safely and conveniently via Apple® CarPlay® or Android Auto®, even when driving. In addition, you can keep an eye on your vehicle at all times and call up vehicle information conveniently from home or when on the go.



Ambient lighting.

Showcases the interior according to your personal preferences or current mood. The 64 colours of the ambient lighting create fascinating colour schemes, for example in the illuminated air vents, doors or the dashboard.

Burmester® surround sound system.

The high-performance speakers deliver first-class surround sound. This can be specifically optimised for the front and rear seats, thereby intensifying the listening experience. A level of quality that is also visible, thanks to the high-quality Burmester lettering.



MULTIBEAM LED.

Giving you perfect visibility: the adaptive MULTIBEAM LED headlamps with individually controllable LEDs react to the traffic situation. Partial main beam masks out other road users without dazzling them. The cornering and active light functions also illuminate the field of vision optimally, allowing faster identification of hazards.

Wheels of up to 19 inches in size.

Ready to conquer the roads: the optionally available 48.26 cm (19-inch) wheels do not only look incredibly good, they also provide for a more full-on, sporty driving feel.

Standard equipment and appointments.

You already get a great deal of CLA without selecting a single item on the options list. That's because the vehicle is extremely generous in terms of its standard specification. A sporty appearance is guaranteed, courtesy of the the diamond radiator grille, LED daytime running lamps and light-alloy wheels. Active Brake Assist stands for the car's high standard of safety.



The AMG Line.

With the AMG Line you are making a clear statement in favour of performance, both inside and out. The AMG bodystyling, above all, with special front and rear aprons, lends the car a resemblance to AMG models. The technical features too, including a lowered, sportily tuned suspension and the Direct-Steer system, serve to intensify the driving experience.



The Progressive design and equipment line.

The Progressive design and equipment line substantially enhances your car. Added value you can see and feel. From every perspective, the excitement and high-quality technical appeal associated with a sporty coupé are intensified. In addition, the line offers the option of further attractive combinations both inside and out – for example with the Leather package and Night package.



The Night package.

The Night package adds further attractive features. Your car enhances its sportiness and individuality with the aesthetic highlights. Numerous elements are finished in black or high-gloss black.





Suspension with adaptive damping adjustment.

If you so wish, the damping can adapt fully to your driving style and the road via the suspension settings and can actively support the CLA's driving dynamics.

The weight and noise-optimised components are designed to combine agile handling characteristics, driving safety and comfort as ideally as possible.



DYNAMIC SELECT.

Just drive as you want to. At the press of a button DYNAMIC SELECT offers different drive programs with pre-set options for the engine, transmission, suspension and steering, for instance. In “Sport” mode the vehicle is more dynamic, while in the standard “Comfort” mode the set-up is exceptionally balanced. “ECO”, on the other hand, places the emphasis on maximum efficiency and saves fuel and money.

Instant lift-off.

Every Mercedes-AMG is a masterpiece in its own right, with an unmistakable character. What unites our performance vehicles and sports cars is their irrepressible sporting spirit. Their passion for top performance. It is generated at the point where engineering skill meets a very special attitude: the spirit of AMG. We believe that you have to keep on challenging limits in order to achieve new goals. We accept nothing as a given. Because limits are imposed by people, and it's also people who can overcome them. It's this attitude that enables us to achieve outstanding performance for motor racing – and for the road.

Welcome to the world of AMG.

www.mercedes-amg.com



AMG
DRIVING PERFORMANCE



Technical data.

	Petrol engines				
	CLA 200	CLA 250 4MATIC	Mercedes-AMG 35 4MATIC	Mercedes-AMG 45 4MATIC	Mercedes-AMG 45 S 4MATIC
Displacement (cc)	1332	1991	1991	1991	1991
Rated output ¹ (kW [hp] at rpm)	120 (163) 5500	165 (224) 5500	225 (306) 5800	285 (387) 6500	310 (421) 6750
Acceleration from 0 to 100 km/h (s)	8.2	6.3	4.9	4.1	4.0
Top speed (km/h)	229	250	250	250	270
Fuel consumption ⁴ (l/100 km)					
Urban	6.7-6.6	9.2-8.5	9.5-9.3	10.6-10.6	10.6-10.6
Extra-urban	5.2-4.6	5.6-5.0	6.3-6.0	6.9-6.7	6.9-6.8
Combined	5.8-5.3	6.9-6.3	7.4-7.2	8.3-8.2	8.3-8.2
Combined CO ₂ emissions ⁴ (g/km)	133.0-122.0	158.0-144.0	170.0-165.0	189.0-187.0	190.0-187.0
Emissions class ⁵ /efficiency class ⁶	Euro 4/ B	Euro 4/ C	Euro 4/ D	Euro 4/ E	Euro 4/ E

The best for the engine:
Mercedes-Benz genuine engine oils.

¹ Information about the rated output according to Regulation (EC) No. 715/2007 in the currently valid version. ² Available temporarily. ³ Electronically governed. ⁴ The stated figures were determined according to the prescribed measurement method. They constitute the "NEDC CO₂ figures" pursuant to Article 2 No. 1 Implementing Regulation (EU) 2017/1153. Fuel consumption figures have been calculated on this basis. More information about the official fuel consumption and the official specific CO₂ emissions of new passenger cars is available in the publication entitled "Leitfaden über den Kraftstoffverbrauch, die CO₂-Emissionen und den Stromverbrauch neuer Personenkraftwagen" ["Guidelines concerning the fuel consumption, CO₂ emissions and electricity consumption of new passenger cars"], available free of charge at all retailers and from Deutsche Automobil Treuhand GmbH (www.dat.de). The figures are not based on an individual vehicle and do not constitute part of the product offer; they are provided solely for purposes of comparison between different vehicle models. The figures will vary according to the optional equipment selected. ⁵ Information only valid within the European Union. May vary from country to country. ⁶ Determined on the basis of the measured CO₂ emissions, taking into consideration the vehicle mass. Only valid for Germany. *Weighted electrical consumption (kWh/100 km)/Electric range (km): XXXXXXXX.
Further technical data may be found at

Dimensions.

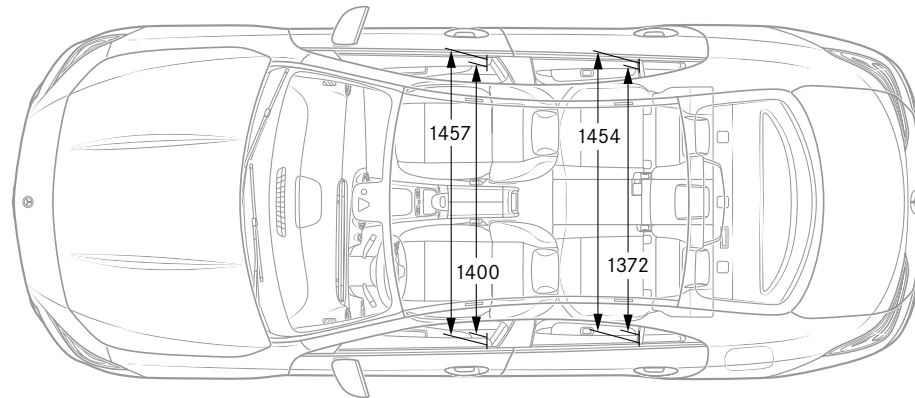
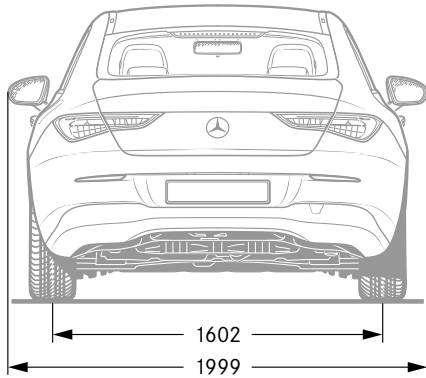
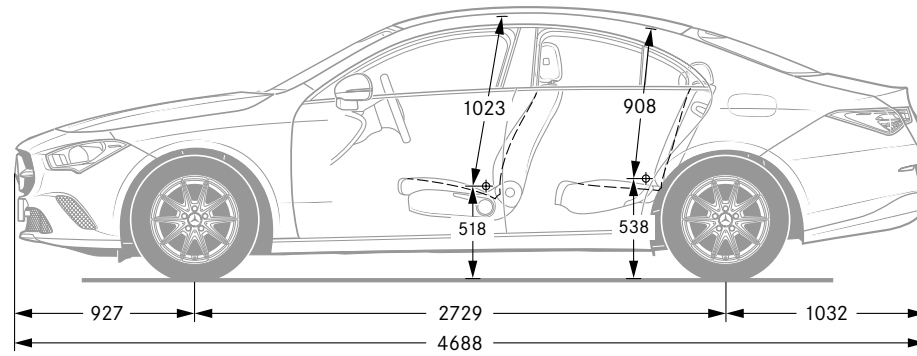
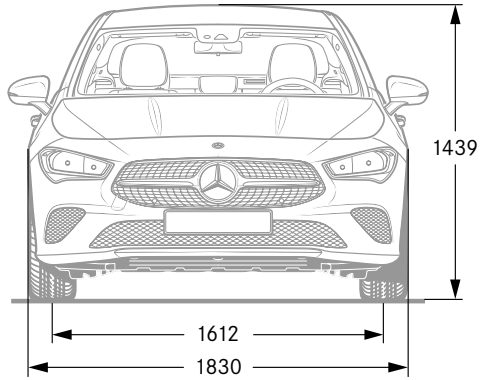

All figures in millimetres. The pictured dimensions are mean values. They are valid for vehicles in basic specification and in unladen condition.



SPORT - FOR - GOOD

Mercedes-Benz AG is one of the founding partners of the worldwide "Laureus Sport for Good Foundation", which was established in 2000. It is the Mercedes-Benz brand's most important social initiative. Laureus Sport for Good supports children and young people in need through social sports projects, opening up new perspectives and imparting important values such as team spirit, respect and determination. "Change the Game for Kids" is our mission statement which we wish to share with you.

Please note: Changes may have been made to the product since the editorial deadline on 12.05.2020. The manufacturer reserves the right to make changes to the design, form, colour and the product specification during the delivery period, provided these changes, while taking into account the interests of the seller, can be deemed reasonable with respect to the buyer. Where the seller or the manufacturer uses symbols or numbers to describe an order or the

subject of an order, no rights may be derived solely from these. The illustrations may show accessories and items of optional equipment which are not part of standard specification. For the definitive latest information, please contact your nearest authorised Mercedes-Benz AG dealer.