

The B-Class



Mercedes-Benz





Justify nothing.

If everything feels perfect, there's no need to offer justification for anything. Not for your lifestyle. Not for your sense of style. And least of all for a car that offers the ultimate in safety and comfort. The most intuitive operating concept in its class, and styling that is more dynamic than ever before. Discover the B-Class from Mercedes-Benz.





As you like it.

Emphatically sporty, exceptionally elegant or dynamically modern: the exterior of the B-Class is what you make it. Choose between the AMG Line, Style and Progressive. And combine these as you wish with optional equipment and packages. To make the B-Class your very own signature B-Class. Exactly to your taste.







This same sort of variability
is also true of the ride.

A tap on the DYNAMIC SELECT switch is all it takes for a sporty set-up. Optional 4MATIC all-wheel drive engages automatically for added traction. And two cylinders can be shut down automatically to save fuel. The B-Class doesn't just offer a thrilling driving experience, but one that is tailored perfectly to you and your driving situation.





Family cars are not what they used to be.

Elegant trim elements, sensually pure lines and a dynamic “wrap-around” design embrace you as soon as you get into the car. The state-of-the-art steering wheel with Touch Control buttons and the optional Widescreen Cockpit with intuitive voice-operated control are there to take the pressure off you when driving. At a touch, or with just two little words: “Hey Mercedes”.



Come on in!

Whether with its raised seating position, its excellent all-round visibility or its extra-low load compartment sill: the B-Class simply gives you more freedom. A variable load compartment floor, along with rear seats that split in up to three ways, also enhance the car's flexibility and space.

The image shows the front interior of a Mercedes-Benz B-Class. The seats are upholstered in a light beige, perforated leather with a subtle pattern. The dashboard is dominated by a large, curved digital display showing various vehicle metrics and navigation information. Below the screen are three circular air vents with a glowing orange-red light. The steering wheel is black with the Mercedes-Benz logo in the center. The overall design is modern and luxurious, with a focus on comfort and technology.

Your Personal Assistant is already to hand.

Apart from allowing fully intuitive operation, the B-Class also keeps adapting to your needs and habits every day. It notes your route to the office, for example, and can offer a faster route automatically in case of a traffic hold-up. You can also ask it to combine several systems at once into a revitalising or relaxing convenience program.



A silver Mercedes-Benz B-Class van is shown from a rear three-quarter perspective, driving on a city street. The car is in motion, as indicated by the blurred background of buildings and the road. The license plate is 'S MB 2472'. The Mercedes-Benz logo is visible on the rear of the van.

Because safety is sometimes everything.

The B-Class can be optionally fitted with a series of assistance systems that are now able to react even more intelligently, precisely and quickly. At speeds of up to 210 km/h these will automatically keep you a set distance behind other traffic, change lane, start up again in queuing traffic or even brake if need be. This means you and your passengers are always in the best of hands.



Exemplary safety with Mercedes-Benz Intelligent Drive systems.

In the rush hour, during a long drive at night or on an unfamiliar route, your B-Class noticeably takes the strain out of driving, particularly in stressful situations. It's all down to a concept that makes every journey in a Mercedes-Benz a safer and exceptional experience: Mercedes-Benz Intelligent Drive. Because the time you spend behind the wheel is your time. Time for relaxation. Time to replenish your energy. So that, first and foremost, you reach your destination safely, but are also relaxed when you get there.



EQUIPMENT HIGHLIGHTS – DRIVING ASSISTANCE SYSTEMS

The **Driving Assistance package** is a combination of sophisticated safety and assistance systems that can detect danger and issue an alert, or even brake, in an emergency.

PRE-SAFE® system: The innovative PRE-SAFE® Sound system generates a noise from the loudspeakers that can trigger a protective reflex: your auditory system briefly disconnects, thereby protecting itself from the loud noise of a crash.

Traffic Sign Assist: The camera and navigation data keep an eye on the maximum allowed speed – so you never miss the speed-limit signs among the sea of other signs on the road.

Park with ease. The duo of **Active Parking Assist** and **360° camera** supports you in looking for a parking space, as well as when entering and leaving a parking space or manoeuvring.

The all-round view, thanks to the 360° camera including a virtual bird's-eye view, is particularly impressive.



MBUX (Mercedes-Benz User Experience).

Apart from allowing fully intuitive operation, the B-Class also keeps adapting to your needs and habits every day. It notes your route to the office, for example, and can offer a faster route automatically in case of a traffic hold-up. This all forms part of the revolutionary MBUX (Mercedes-Benz User Experience). A multimedia system that keeps learning about you and your preferences. Until the B-Class knows you almost better than you do yourself.

EQUIPMENT HIGHLIGHTS – CONTROL AND DISPLAY CONVENIENCE

Widescreen Cockpit with LINGUATRONIC voice control system: Thanks to MBUX voice control, the B-Class listens to you and understands you without having to learn any commands beforehand. Two words from you are all it takes: “Hey Mercedes” – and the B-Class is all ears and ready for anything.

Touch Control concept: You’ll find hardly any conventional buttons and controls in the B-Class cockpit. All functions can be controlled intuitively. With a touchscreen or the touchpad, for example, which allow you to operate and adjust almost anything in the car using a single finger. The display styles, the ambient lighting or the infotainment system, for example. You can now also control these features directly via Touch Control on the steering wheel. All without having to take your hands off the wheel.

Augmented Video: MBUX Augmented Reality Navigation helps you to keep control of things even in complex traffic situations. To achieve this, the technology networks the virtual world with the real one and incorporates graphic navigation and traffic information into live images of the vehicle’s surroundings, as shown to you on the media display.

Display styles: The cockpit welcomes you with two fully digital displays that present a fascinating spectacle as a single unit. There is a choice of three styles for the instrument display – “Classic”, “Sport” and “Discreet Mode”, which you can switch between according to your mood, the course of the journey or the given driving situation.





Ambient lighting in 64 colours.

With its pleasant, indirect light, the optional ambient lighting creates a unique atmosphere throughout the interior. To suit your personal preference or mood. There is a range of 64 colours, while you can also choose between stylishly coordinated colour schemes and lighting effects that immerse the ventilation outlets, the doors and the instrument panel, for example, in a fascinating interplay of colours. This means that you and the B-Class are always shown in the best light.



ENERGIZING package Plus.

An attentive, focused driver is one of the most important contributory factors to safer driving. With this in mind, the optional ENERGIZING package Plus combines various systems – air conditioning, ambient light, music and seating comfort – into programmes lasting several minutes, which are designed to vitalise or relax you.



MULTIBEAM LED headlamps.

Apart from setting a new benchmark in design, the MULTIBEAM LED headlamps also illuminate the road better than any conventional headlamps. This means you can recognise dangers even more quickly.



Panoramic sliding sunroof.

Experience direct open-top motoring pleasure, almost like in a cabriolet or roadster – refreshing and draught-free. Simply push back the panoramic sliding sunroof to any position. Even if the panoramic sliding sunroof is closed, its transparency brings more light and brightness into the interior, lightening your mood, too.

Standard equipment and appointments.

You already get a lot of B-Class without selecting a single item on the options list – the vehicle has an extremely generous standard specification. The high standard of safety is reflected in the Active Brake Assist. Practical benefits: the 40:20:40 split of the rear-seat backrests and the height-adjustable load compartment floor.



The Style design and equipment line.

With the Style design and equipment line your car stands out from the standard version. A youthfully cool look inside and out. This includes additional features such as the 16-inch light-alloy wheels plus upholsteries and topstitching in trendy colours which are exclusive to the line.



The Progressive design and equipment line.

The Progressive design and equipment line substantially enhances your car. Added value you can see and feel. From every perspective the excitement and high-quality engineering associated with a desirable Sports Tourer are intensified. In addition, the line opens up further attractive combinations both inside and out – for example with the Leather package and Night package.



The AMG Line design and equipment line.

The AMG Line enhances the attractive sporty presence both on the exterior and in the interior. The AMG bodystyling and the diamond radiator grille with single louvre, in particular, are exclusive features. The lowered, dynamically tuned suspension and direct steering intensify your driving experience. The ideal complement: the sports steering wheel with flattened bottom section, trimmed in elegant nappa leather.



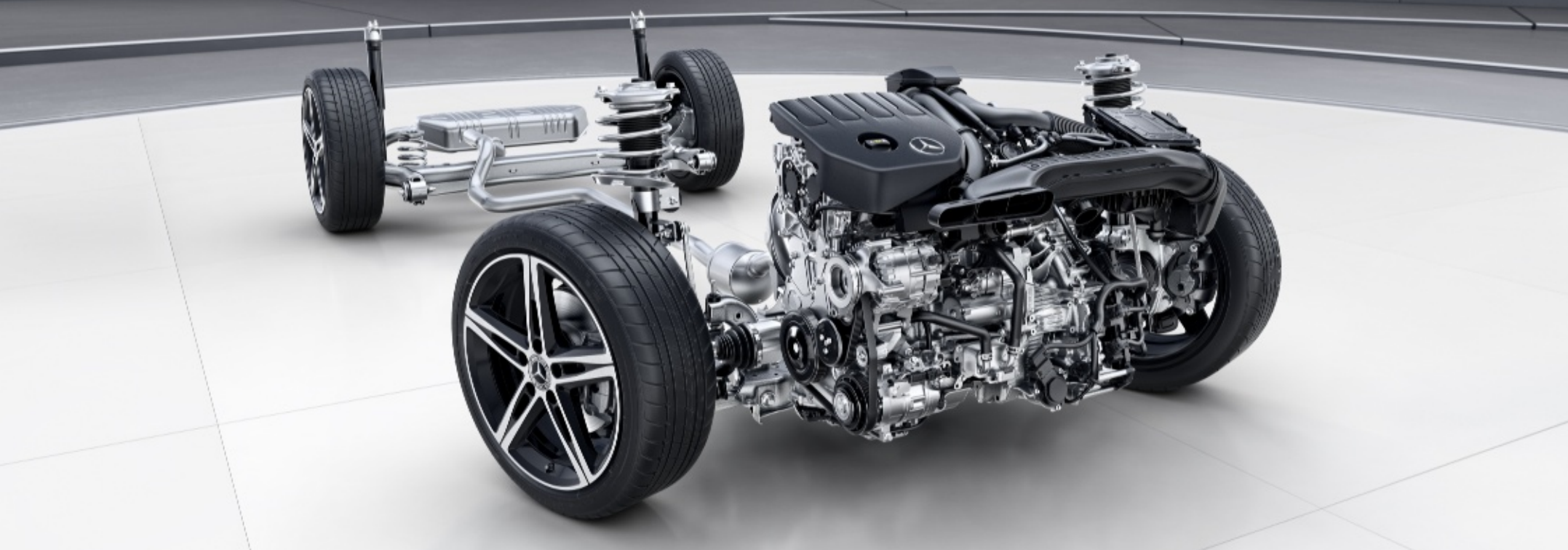

Comfort suspension.

Enjoy a high level of comfort on long motorway stretches, and negotiate tight bends with sporty flair. The balanced comfort suspension provides an impressive mix of responsive suspension reserves with excellent driving stability. This makes for a safe trip while at the same time providing a great deal of driving pleasure.

SUSPENSION WITH ADAPTIVE DAMPING SYSTEM

Would you like more fun at the wheel when cornering or high comfort on long journeys? The suspension with adjustable damping offers this exciting choice. The DYNAMIC SELECT rocker switch in the centre console is used to select the program and thus the characteristics: "Eco", "Comfort" or "Sport". As though you had two suspensions in one car – refined sportiness.

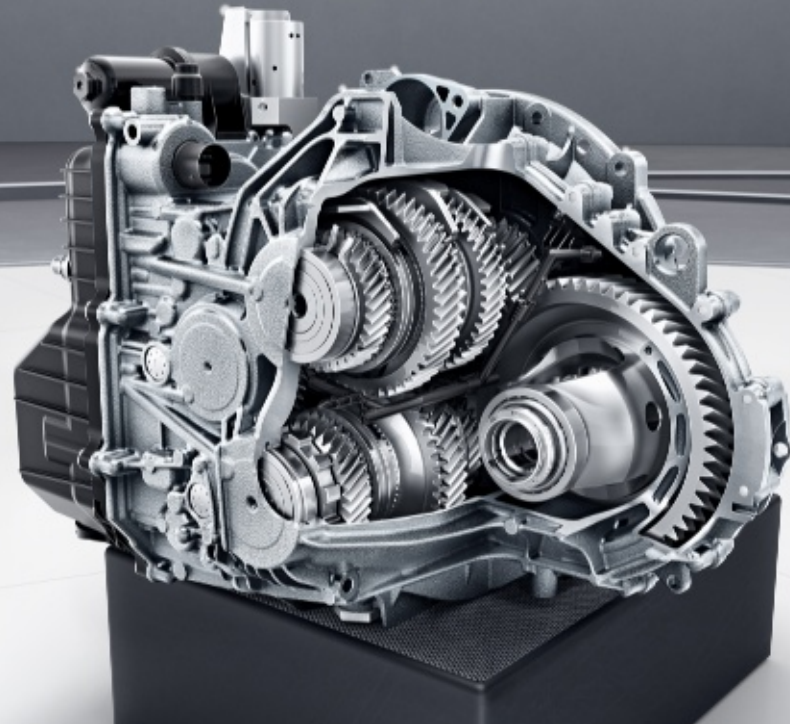

8G-DCT.

An automatic transmission that adapts to your wishes: by changing the driving program, you also change the characteristics of the dual clutch transmission. According to your selection, it uses the 8 gears to deliver efficient driving at low engine speeds or impressive dynamic performance. Because the next gear is always already preselected, acceleration is completely smooth.

COMPONENTS

8-speed dual clutch transmission made up of two sub-transmissions, each with its own clutch

8 forward gears and 1 reverse gear

DIRECT SELECT selector lever on the steering wheel

High-quality steering-wheel shift paddles – on the left to shift down and on the right to shift up

Technical data.

Displacement (cc)
Rated output ¹ (kW [hp] at rpm)
Acceleration from 0 to 100 km/h (s)
Top speed (km/h)
Fuel consumption ⁴ (l/100 km)
Urban
Extra-urban
Combined
Combined CO ₂ emissions ⁴ (g/km)
Emissions class ⁵ /efficiency class ⁶

Petrol engines

B 200	B 250	B 250 4MATIC
1332	1991	1991
120 (163) 5500	165 (224) 5500	165 (224) 5500
8.2	6.4	6.4
223	250	250
6.7-6.6	8.4-7.9	9.0-8.9
5.3-4.7	5.4-4.9	5.8-5.1
5.9-5.4	6.5-6.0	7.1-6.5
134-124	148-137	162-148
Euro 4/ B	Euro 4/ B	Euro 4/ C

The best for the engine:
Mercedes-Benz genuine engine oils.

¹ Information about the rated output according to Regulation (EC) No. 715/2007 in the currently valid version. ² Available temporarily. ³ Electronically governed. ⁴ The stated figures were determined according to the prescribed measurement method. They constitute the "NEDC CO₂ figures" pursuant to Article 2 No. 1 Implementing Regulation (EU) 2017/1153. Fuel consumption figures have been calculated on this basis. More information about the official fuel consumption and the official specific CO₂ emissions of new passenger cars is available in the publication entitled "Leitfaden über den Kraftstoffverbrauch, die CO₂-Emissionen und den Stromverbrauch neuer Personenkraftwagen" ["Guidelines concerning the fuel consumption, CO₂ emissions and electricity consumption of new passenger cars"], available free of charge at all retailers and from Deutsche Automobil Treuhand GmbH (www.dat.de). The figures are not based on an individual vehicle and do not constitute part of the product offer; they are provided solely for purposes of comparison between different vehicle models. The figures will vary according to the optional equipment selected. ⁵ Information only valid within the European Union. May vary from country to country. ⁶ Determined on the basis of the measured CO₂ emissions, taking into consideration the vehicle mass. Only valid for Germany. *Weighted electrical consumption (kWh/100 km)/Electric range (km): XXXXXXXX.
Further technical data may be found at

Dimensions.

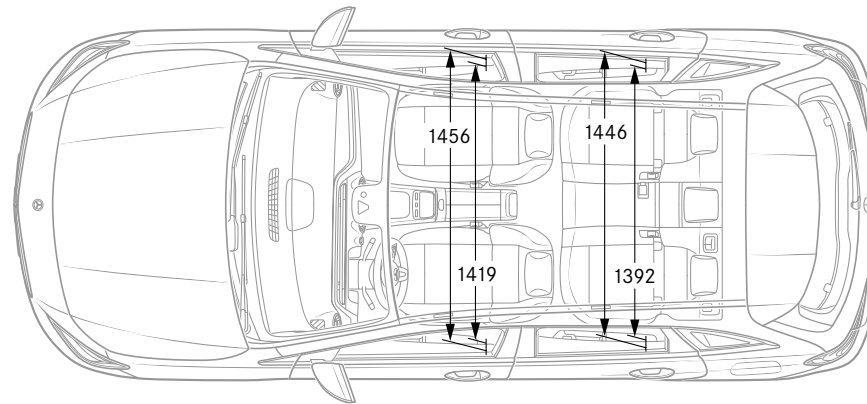
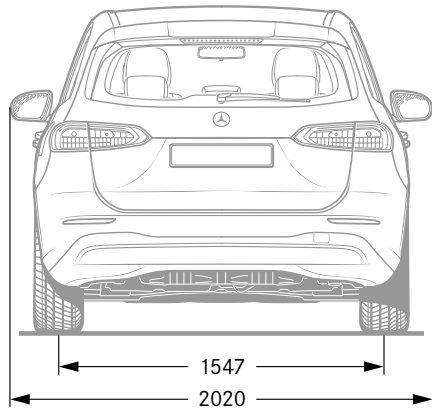
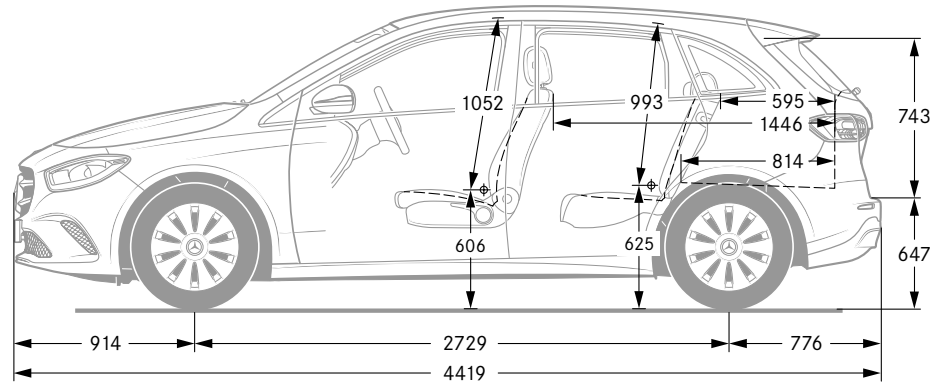
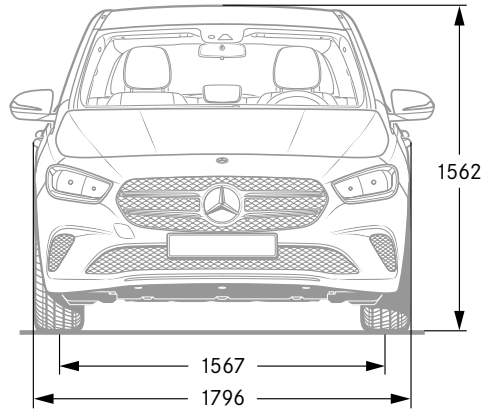

All figures in millimetres. The illustrated dimensions are mean values. They are valid for vehicles in basic specification and in unladen condition.



SPORT — F O R — GOOD

Mercedes-Benz is one of the founding partners of the worldwide “Laureus Sport for Good Foundation”, which was established in 2000. It is the Mercedes-Benz brand’s most important social initiative. Laureus Sport for Good supports children and young people in need through social sports projects, opening up new perspectives and imparting important values such as team spirit, respect and determination. “Change the Game for Kids” is our mission statement which we wish to share with you.

Please note: changes may have been made to the product since the editorial deadline (02.09.2019). The manufacturer reserves the right to make changes to the design, form, colour and the product specification during the delivery period, provided these changes, while taking into account the interests of the vendor, can be deemed reasonable with respect to the purchaser. Where the seller or the manufacturer uses symbols or numbers to describe an order or the subject of

an order, no rights may be derived solely from these. The illustrations may show accessories and items of optional equipment which are not part of standard specification. For current and more specific information, please contact your nearest authorised Mercedes-Benz sales partner.